

12/28/2023 1:35 AM

s:\projects\tubelite, inc\fb-23-1221 - fb- submittal - f127506 400t series non-impact curtainwall revisions\dwg\TlI028.dwg

TUBELITE[®]

DEPENDABLE

SERIES 400T CURTAIN WALL - SSG (NON-HVHZ) (NON-IMPACT)



3056 WALKER RIDGE DRIVE N.W.
WALKER, MICHIGAN 49544
PH: 800 866 2227 FX: 616 301 0008

INSTALLATION NOTES:

- ONE (1) INSTALLATION ANCHOR IS REQUIRED AT EACH ANCHOR LOCATION SHOWN, UNLESS OTHERWISE STATED.
- THE NUMBER OF INSTALLATION ANCHORS DEPICTED IS THE MINIMUM NUMBERS OF ANCHORS TO BE USED FOR PRODUCT INSTALLATION.
- INSTALL INDIVIDUAL INSTALLATION ANCHORS WITHIN A TOLERANCE OF ±1/2 INCH OF THE DEPICTED LOCATION IN THE ANCHOR LAYOUT DETAIL (I.E., WITH OUT CONSIDERATION OF TOLERANCE). TOLERANCE ARE NOT CUMULATIVE FROM ONE INSTALLATION ANCHOR TO THE NEXT.
- REFER TO SECTION 7 FOR ANCHOR TYPE, SUBSTRATE STRENGTH, EMBEDMENT, & EDGE DISTANCE REQUIREMENTS. FOLLOW MANUFACTURER INSTALLATION INSTRUCTIONS FOR INSTALLATION OF ANCHORS.
- MINIMUM EMBEDMENT AND EDGE DISTANCE EXCLUDE WALL FINISHES, INCLUDING BUT NOT LIMITED TO STUCCO, FOAM, BRICK VENEER, AND SIDING.
- INSTALLATION ANCHORS AND ASSOCIATED HARDWARE MUST BE MADE OF CORROSION RESISTANT MATERIAL OR HAVE A CORROSION RESISTANT COATING.
- INSTALLATION ANCHORS SHALL BE INSTALLED IN ACCORDANCE WITH ANCHOR MANUFACTURER'S INSTALLATION INSTRUCTIONS, AND ANCHORS SHALL NOT BE USED IN SUBSTRATES WITH STRENGTHS LESS THAN THE MINIMUM STRENGTH SPECIFIED BY THE ANCHOR MANUFACTURER. ADHESIVE ANCHORS MUST BE INSTALLED BY PERSONNEL CERTIFIED FOR THE SPECIFIED ANCHOR INSTALLATION.

INSTRUCTIONS:

USE CHARTS AS FOLLOW

- DETERMINE DESIGN WIND LOAD REQUIREMENT BASED ON WIND VELOCITY, BLDG. HEIGHT, WIND ZONE USING APPLICABLE ASCE 7 STANDARD.
- SEE CHARTS ON SECTION 6 FOR DESIGN LOAD CAPACITY OF DESIRED GLASS SIZE.
- CHECK MULLION CAPACITY FOR A GIVEN SPACING, HEIGHT, SINGLE SPAN, TWIN SPAN, MULTIPLE SPANS AND CORNERS ON SECTIONS 3 & 4.
- USING HEAD/SILL ANCHOR DETAILS, SELECT ANCHOR OPTION FROM TABLES ON SECTION 7 WITH DESIGN RATING MORE THAN DESIGN LOAD SPECIFIED IN STEP 1 ABOVE.
- CHECK INTERMEDIATE ANCHOR CAPACITY FOR MULTIPLE SPANS USING CHARTS OR DETAILS ON SECTION 8.
- THE LOWEST VALUE RESULTING FROM STEPS 2, 3, 4 AND 5 SHALL APPLY TO ENTIRE SYSTEM.

GENERAL NOTES:

- THE PRODUCT SHOWN HEREIN IS DESIGNED AND MANUFACTURED TO COMPLY WITH THE CURRENT FLORIDA BUILDING CODE, **EXCLUDING** REQUIREMENTS FOR HVHZ AND HAS BEEN EVALUATED ACCORDING TO THE FOLLOWING:
 - AAMA 501-15
 - AAMA 501.1-17
 - AAMA 501.4-09
 - AAMA 501.5-07
 - AAMA 501.7-11
 - ASTM E283-19
 - ASTM E330-14(21)
 - ASTM E331-00(16)
- ADEQUACY OF THE EXISTING STRUCTURAL CONCRETE/MASONRY, 2X AND STEEL STUD FRAMING AS A MAIN WIND FORCE RESISTING SYSTEM CAPABLE OF WITHSTANDING AND TRANSFERRING APPLIED PRODUCT LOADS TO THE FOUNDATION IS THE RESPONSIBILITY OF THE ENGINEER OR ARCHITECT OF RECORD FOR THE PROJECT OF INSTALLATION.
- 2X BUCKS (WHEN USED) SHALL BE DESIGNED AND ANCHORED TO PROPERLY TRANSFER ALL LOADS TO THE STRUCTURE. BUCK DESIGN AND THE INSTALLATION IS THE RESPONSIBILITY OF THE ENGINEER OR ARCHITECT OF RECORD FOR THE PROJECT OF INSTALLATION.
- THE INSTALLATION DETAILS DESCRIBED HEREIN ARE GENERIC AND MAY NOT REFLECT ACTUAL CONDITIONS FOR A SPECIFIC SITE. IF SITE CONDITION CAUSE INSTALLATION TO DEVIATE FROM THE REQUIREMENTS DETAILED HEREIN, A LICENSED ENGINEER OR ARCHITECT SHALL PREPARE SITE SPECIFIC DOCUMENTS FOR USE WITH THIS DOCUMENT.
- APPROVED IMPACT PROTECTIVE SYSTEM **IS REQUIRED** TO PROTECT THIS PRODUCT IN AREAS REQUIRING IMPACT RESISTANCE.
- MATERIALS INCLUDING BUT NOT LIMITED TO STEEL/METAL SCREWS, THAT COME INTO CONTACT WITH OTHER DISSIMILAR MATERIALS SHALL MEET THE REQUIREMENTS OF THE CURRENT FLORIDA BUILDING CODE.

TABLE OF CONTENTS	
SECTION	SECTION DESCRIPTION
1	COVER SHEET & GENERAL NOTES
2	ELEVATIONS
3	HORIZONTAL SECTIONS
4	VERTICAL SECTIONS
5	DOOR SECTION DETAILS
6	GLAZING DETAILS
7	ANCHOR DETAILS
8	WIND/DEAD LOAD ANCHOR DETAILS

TITLE: SERIES 400T CURTAIN WALL - SSG (NON-HVHZ) (NON-IMPACT)

COVER SHEET & GENERAL NOTES

PREPARED BY: BUILDING DROPS, INC.
1900 NE MIAMI CT., STE. 2-15
MIAMI, FL 33132
PH: (954)399-8478
FAX: (954)744-4738
WEB: www.buildingdrops.com

REMARKS	BY	DATE

THE INSTALLATION DETAILS DESCRIBED HEREIN ARE GENERIC AND MAY NOT REFLECT ACTUAL CONDITIONS FOR A SPECIFIC SITE. IF SITE CONDITIONS CAUSE INSTALLATION TO DEVIATE FROM THE REQUIREMENTS DETAILED HEREIN, A LICENSED ENGINEER OR ARCHITECT SHALL PREPARE SITE SPECIFIC DOCUMENTS FOR USE WITH THIS DOCUMENT

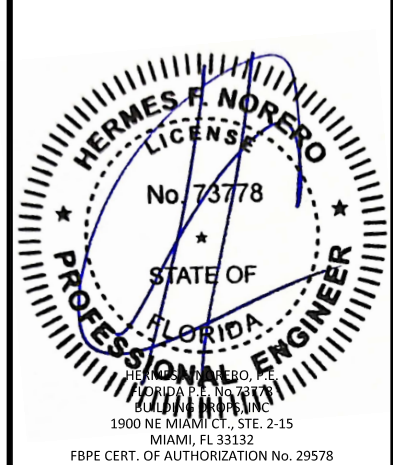

FL #: **FL27506**

DATE: **12.21.23**

DWG. BY: **MS** CHK. BY: **HFN**

SCALE: **NTS**

DWG. #: **TLI028**

SECTION
1.0
[PAGE 1 of 25]

TITLE:
SERIES 400T CURTAIN WALL - SSG
(NON-HVHZ) (NON-IMPACT)

ELEVATIONS

PREPARED BY:
BUILDING DROPS, INC.
1900 NE MIAMI CT., STE. 2-15
MIAMI, FL 33132
PH: (954)399-8478
FAX: (954)744-4738
WEB: www.buildingdrops.com



REMARKS	BY	DATE

THE INSTALLATION DETAILS DESCRIBED HEREIN ARE
GENERIC AND MAY NOT REFLECT ACTUAL CONDITIONS FOR
A SPECIFIC SITE. IF SITE CONDITIONS CAUSE INSTALLATION
TO DEVIATE FROM THE REQUIREMENTS DETAILED HEREIN, A
LICENSED ENGINEER OR ARCHITECT SHALL PREPARE SITE
SPECIFIC DOCUMENTS FOR USE WITH THIS DOCUMENT

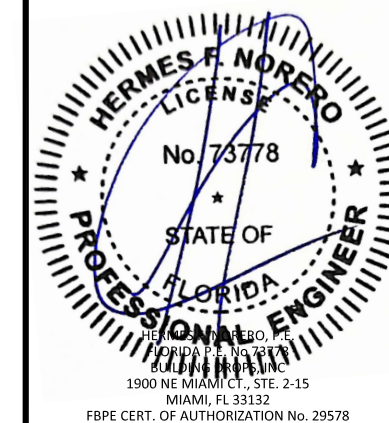

FL #:
FL27506

DATE: **12.21.23**

DWG. BY:
MS

CHK. BY:
HFN

SCALE: **NTS**

DWG. #: **TLI028**

SECTION

2.0

[PAGE 2 of 25]

AVERAGE MULLION SPACING
TYP. MULL. (W) = $\frac{W2 + W3}{2}$ OR $\frac{W4 + W5}{2}$
JAMB MULL. (W) = $\frac{W3}{2}$ OR $\frac{W4}{2}$ OR $\frac{W5}{2}$
OUTSIDE CORNER MULL. (W) = $\frac{W1 + W2}{2}$

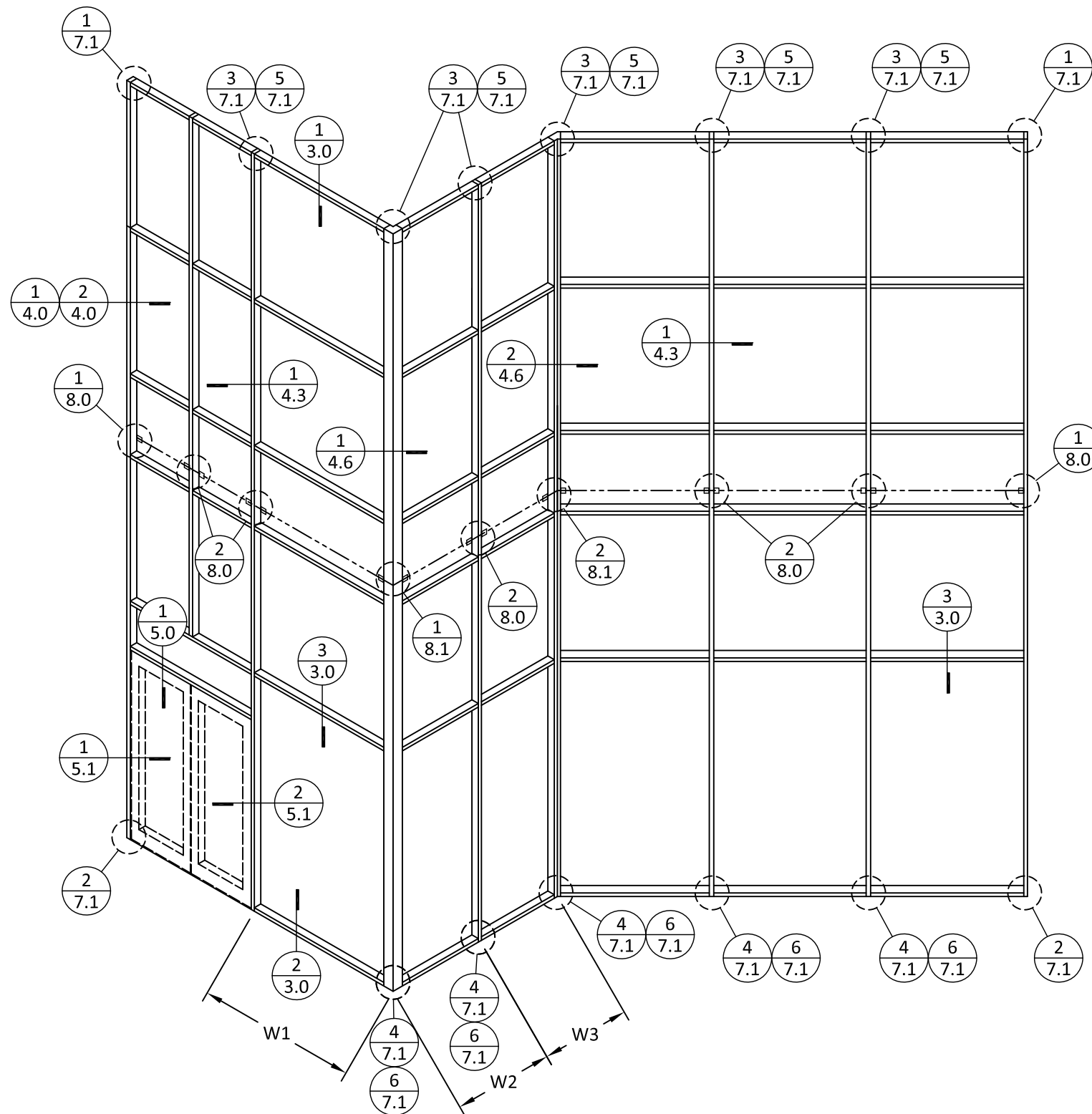

TYPICAL TWIN SPAN

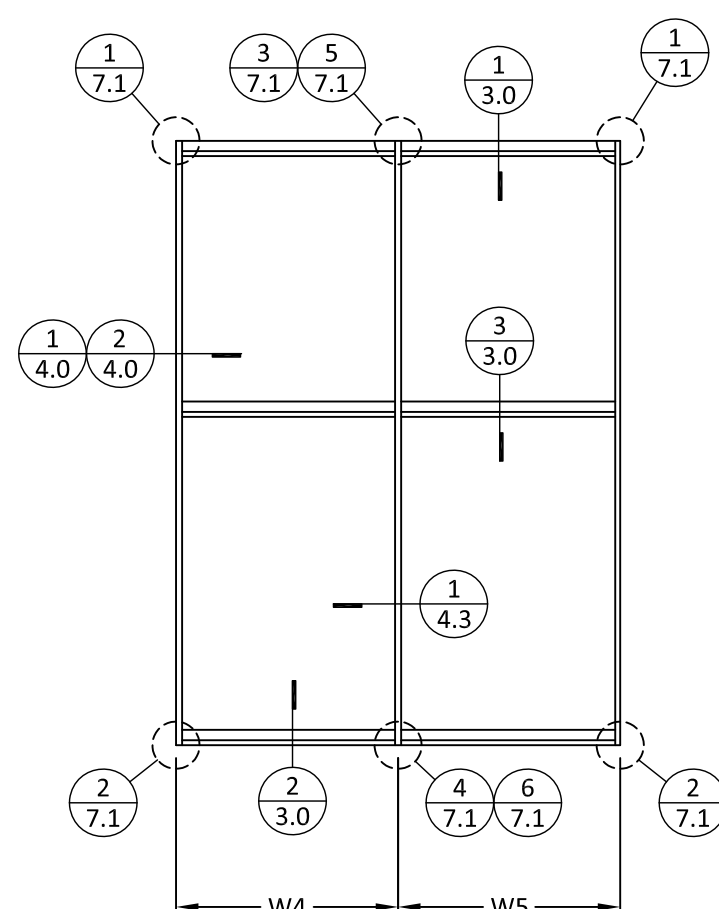

TYPICAL SINGLE SPAN

s:\projects\tubelite, inc\lbc-23-1221 - fbc submittal - f127506 400t series non-impact curtainwall revisions\dwgs\tli028.dwg 12/28/2023 1:35 AM

HORIZONTAL SECTIONS

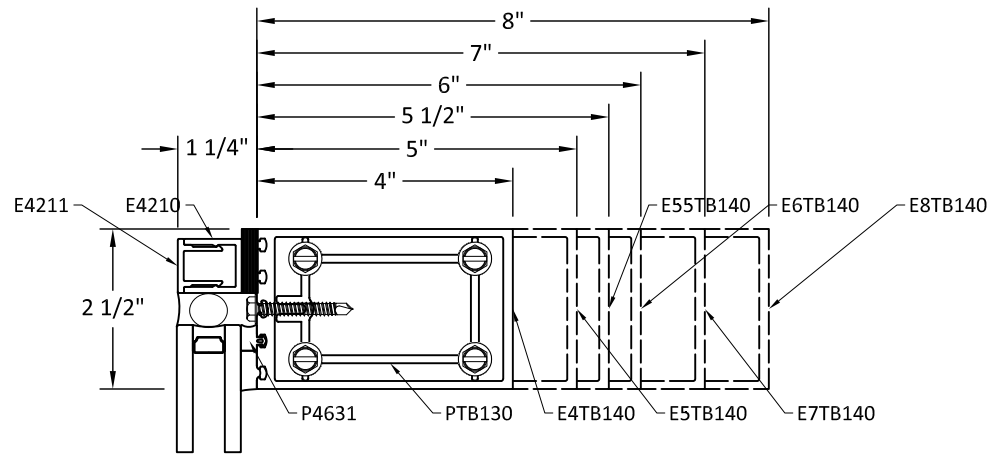

1
3.0 HEAD
STRUCTURAL SILICONE GLAZE

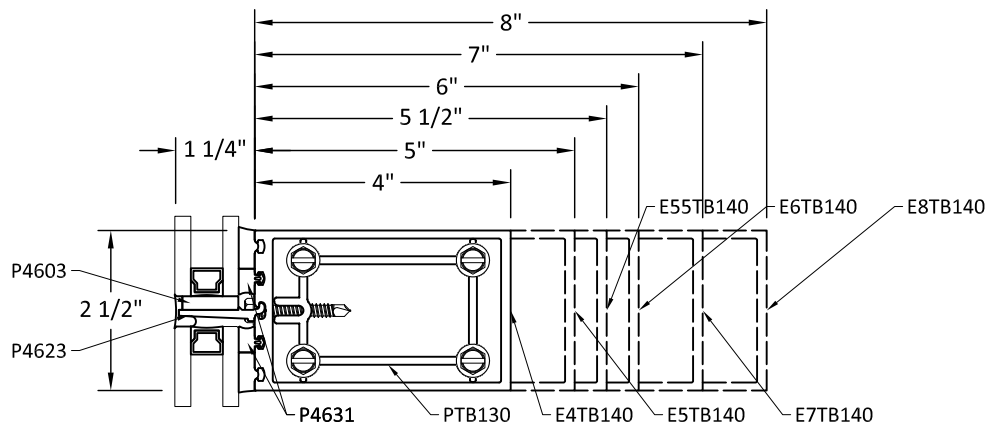

3
3.0 MULLION
HORIZONTAL INTERMEDIATE MEMBER

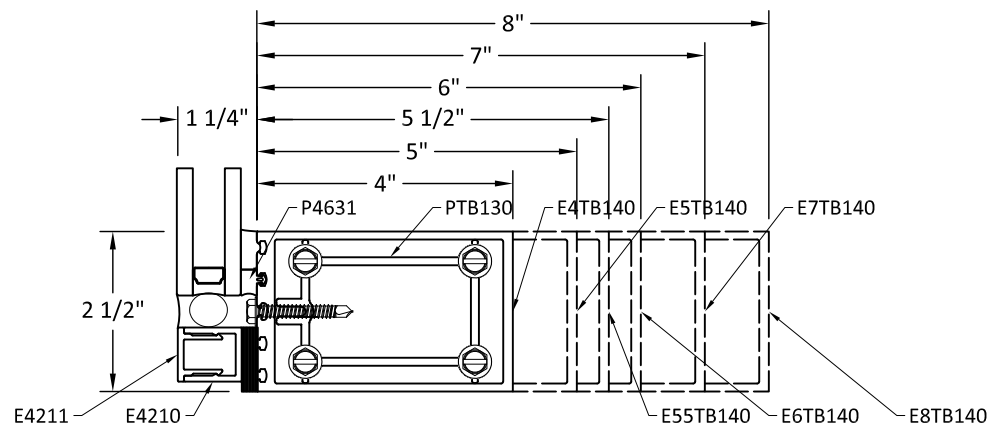

2
3.0 SILL
STRUCTURAL SILICONE GLAZE

TUBELITE®
DEPENDABLE
LEADERS IN ECO-EFFICIENT STOREFRONT,
CURTAINWALL AND ENTRANCE SYSTEMS

3056 WALKER RIDGE DRIVE N.W.
WALKER, MICHIGAN 49544
PH: 800 866 2227 FX: 616 301 0008

TITLE:
SERIES 400T CURTAIN WALL - SSG
(NON-HVHZ) (NON-IMPACT)

HORIZONTAL SECTIONS

PREPARED BY:
BUILDING DROPS, INC.
1900 NE MIAMI CT., STE. 2-15
MIAMI, FL 33132
PH: (954)399-8478
FAX: (954)744-4738
WEB: www.buildingdrops.com



REMARKS	BY	DATE

THE INSTALLATION DETAILS DESCRIBED HEREIN ARE
GENERIC AND MAY NOT REFLECT ACTUAL CONDITIONS FOR
A SPECIFIC SITE. IF SITE CONDITIONS CAUSE INSTALLATION
TO DEVIATE FROM THE REQUIREMENTS DETAILED HEREIN, A
LICENSED ENGINEER OR ARCHITECT SHALL PREPARE SITE
SPECIFIC DOCUMENTS FOR USE WITH THIS DOCUMENT

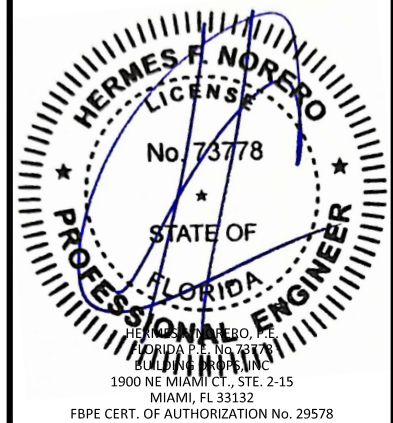

FL #:
FL27506

DATE: **12.21.23**

DWG. BY: **MS** CHK. BY: **HFN**

SCALE: **NTS**

DWG. #: **TLI028**

SECTION
3.0
[PAGE 3 of 25]

s:\projects\tubelite, inc\lbc-23-1221 - fbc-submittal - f127506 400t series non-impact curtainwall revisions\dwg\tli028.dwg 12/28/2023 1:36 AM

HORIZONTAL MULLION CAPACITY

NOMINAL DIMENSIONS (in)		MAX. HORIZONTAL MULLION PRESSURE (+/- PSF)		
MAX. W	L	4" SYSTEM	5"/5-1/2" SYSTEM	6"/7"/8" SYSTEM
120	24	100	100	100
120	30	100	100	100
120	36	84	100	100
120	42	62	76	86
120	48	47	58	66
120	54	36	46	52
120	60	26	35	42

MAX. HORIZONTAL MULLION SPACING 'H' (in)			
WIDTH 'W' (in)	4" SYSTEM	5"/5-1/2" SYSTEM	6"/7"/8" SYSTEM
36	120	120	120
42	120	120	120
48	113	120	120
54	97	120	120
60	78	103	120

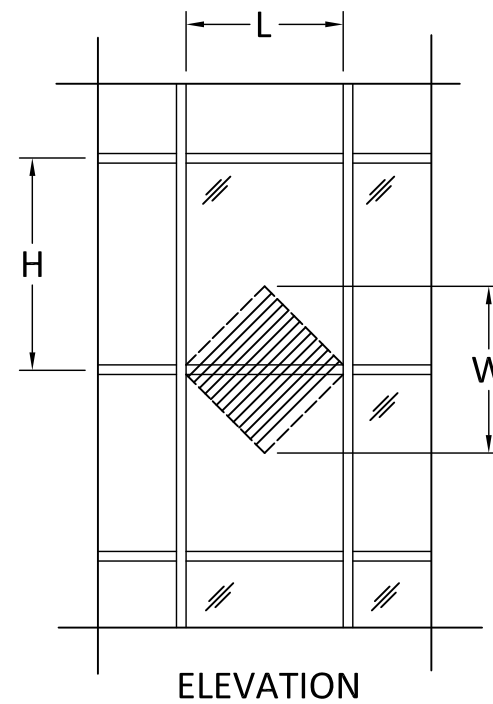

TUBELITE
DEPENDABLE

LEADERS IN ECO-EFFICIENT STOREFRONT,
CURTAINWALL AND ENTRANCE SYSTEMS

3056 WALKER RIDGE DRIVE N.W.
WALKER, MICHIGAN 49544
PH: 800 866 2227 FX: 616 301 0008

TITLE:
SERIES 400T CURTAIN WALL - SSG
(NON-HVHZ) (NON-IMPACT)

HORIZONTAL SECTIONS

PREPARED BY:
BUILDING DROPS, INC.

1900 NE MIAMI CT., STE. 2-15
MIAMI, FL 33132
PH: (954)399-8478
FAX: (954)744-4738
WEB: www.buildingdrops.com



REMARKS	BY	DATE

THE INSTALLATION DETAILS DESCRIBED HEREIN ARE
GENERIC AND MAY NOT REFLECT ACTUAL CONDITIONS FOR
A SPECIFIC SITE. IF SITE CONDITIONS CAUSE INSTALLATION
TO DEVIATE FROM THE REQUIREMENTS DETAILED HEREIN, A
LICENSED ENGINEER OR ARCHITECT SHALL PREPARE SITE
SPECIFIC DOCUMENTS FOR USE WITH THIS DOCUMENT

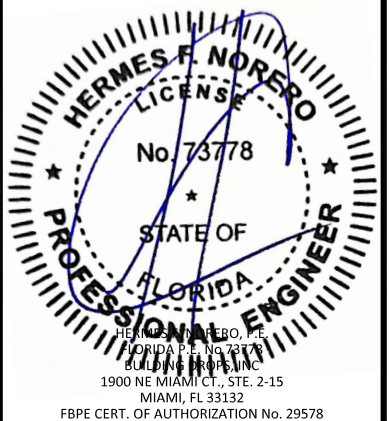

FL #: **FL27506**

DATE: **12.21.23**

DWG. BY: **MS** CHK. BY: **HFN**

SCALE: **NTS**

DWG. #: **TLI028**

SECTION

3.1

[PAGE 4 of 25]

JAMB DETAILS

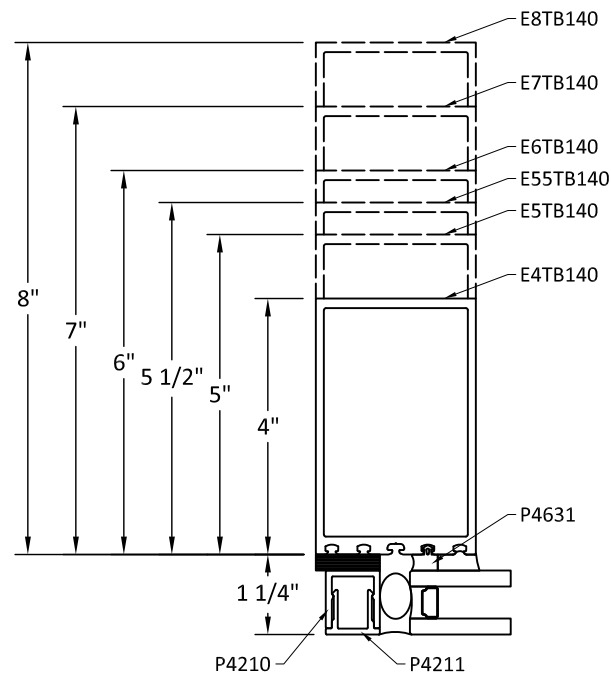

1
4.0

JAMB
STRUCTURAL SILICONE GLAZE

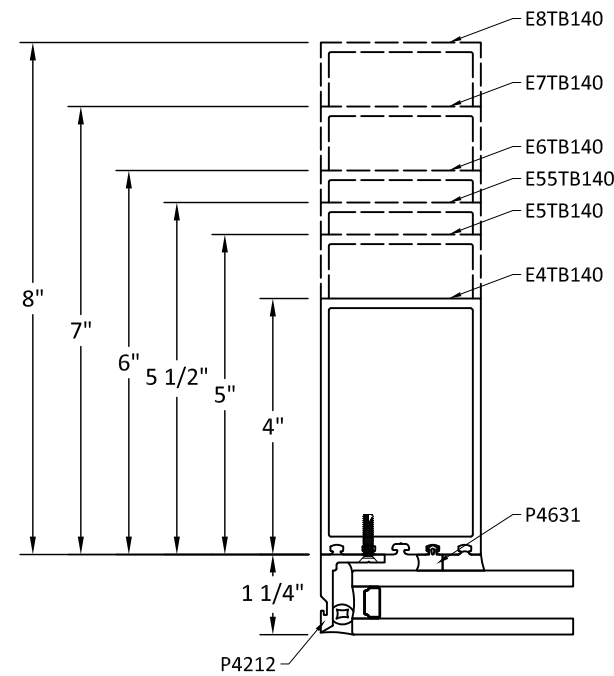

2
4.0

JAMB
STRUCTURAL SILICONE GLAZE
GLASS TO EDGE

TUBELITE®
DEPENDABLE

LEADERS IN ECO-EFFICIENT STOREFRONT,
CURTAINWALL AND ENTRANCE SYSTEMS

3056 WALKER RIDGE DRIVE N.W.
WALKER, MICHIGAN 49544
PH: 800 866 2227 FX: 616 301 0008

TITLE:
SERIES 400T CURTAIN WALL - SSG
(NON-HVHZ) (NON-IMPACT)

VERTICAL SECTIONS

PREPARED BY:
BUILDING DROPS, INC.

1900 NE MIAMI CT., STE. 2-15
MIAMI, FL 33132
PH: (954)399-8478
FAX: (954)744-4738
WEB: www.buildingdrops.com



REMARKS	BY	DATE

THE INSTALLATION DETAILS DESCRIBED HEREIN ARE
GENERIC AND MAY NOT REFLECT ACTUAL CONDITIONS FOR
A SPECIFIC SITE. IF SITE CONDITIONS CAUSE INSTALLATION
TO DEVIATE FROM THE REQUIREMENTS DETAILED HEREIN, A
LICENSED ENGINEER OR ARCHITECT SHALL PREPARE SITE
SPECIFIC DOCUMENTS FOR USE WITH THIS DOCUMENT

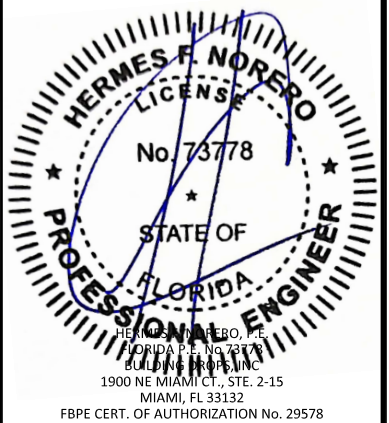

FL #:
FL27506

DATE: **12.21.23**

DWG. BY: **MS** CHK. BY: **HFN**

SCALE: **NTS**

DWG. #: **TLI028**

SECTION
4.0
[PAGE 5 of 25]

s:\projects\tubelite, inc\lbc-23-1221 - fbc submittal - f127506 400t series non-impact curtainwall revisions\dwgs\tli028.dwg 12/28/2023 1:36 AM

JAMB CAPACITY

JAMB LOAD CAPACITY - TWIN SPAN 4" SYSTEM (+/- PSF)		
NOMINAL DIMENSIONS		DESIGN PRESSURE
WIDTH 'W' (in)	SPAN HEIGHT 'H' (in)	EXT. (+) INT. (-)
12	90	100
15		100
18		84
21		72
24		63
27		56
30		51
12	96	100
15		95
18		79
21		68
24		59
27		53
30		47
12	102	100
15		89
18		74
21		64
24		56
27		50
30		45
12	108	100
15		84
18		70
21		60
24		53
27		47
30		42
12	114	97
15		78
18		65
21		56
24		49
27		43
30		39

JAMB LOAD CAPACITY - TWIN SPAN 4" SYSTEM (+/- PSF)		
NOMINAL DIMENSIONS		DESIGN PRESSURE
WIDTH 'W' (in)	SPAN HEIGHT 'H' (in)	EXT. (+) INT. (-)
12	120	83
15		67
18		56
21		48
24		42
27		37
30		33
12	126	72
15		58
18		48
21		41
24		36
27		32
30		29
12	132	63
15		50
18		42
21		36
24		31
27		28
30		25
12	138	55
15		44
18		37
21		31
24		27
27		24
30		22
12	144	48
15		39
18		32
21		28
24		24
27		21
30		19

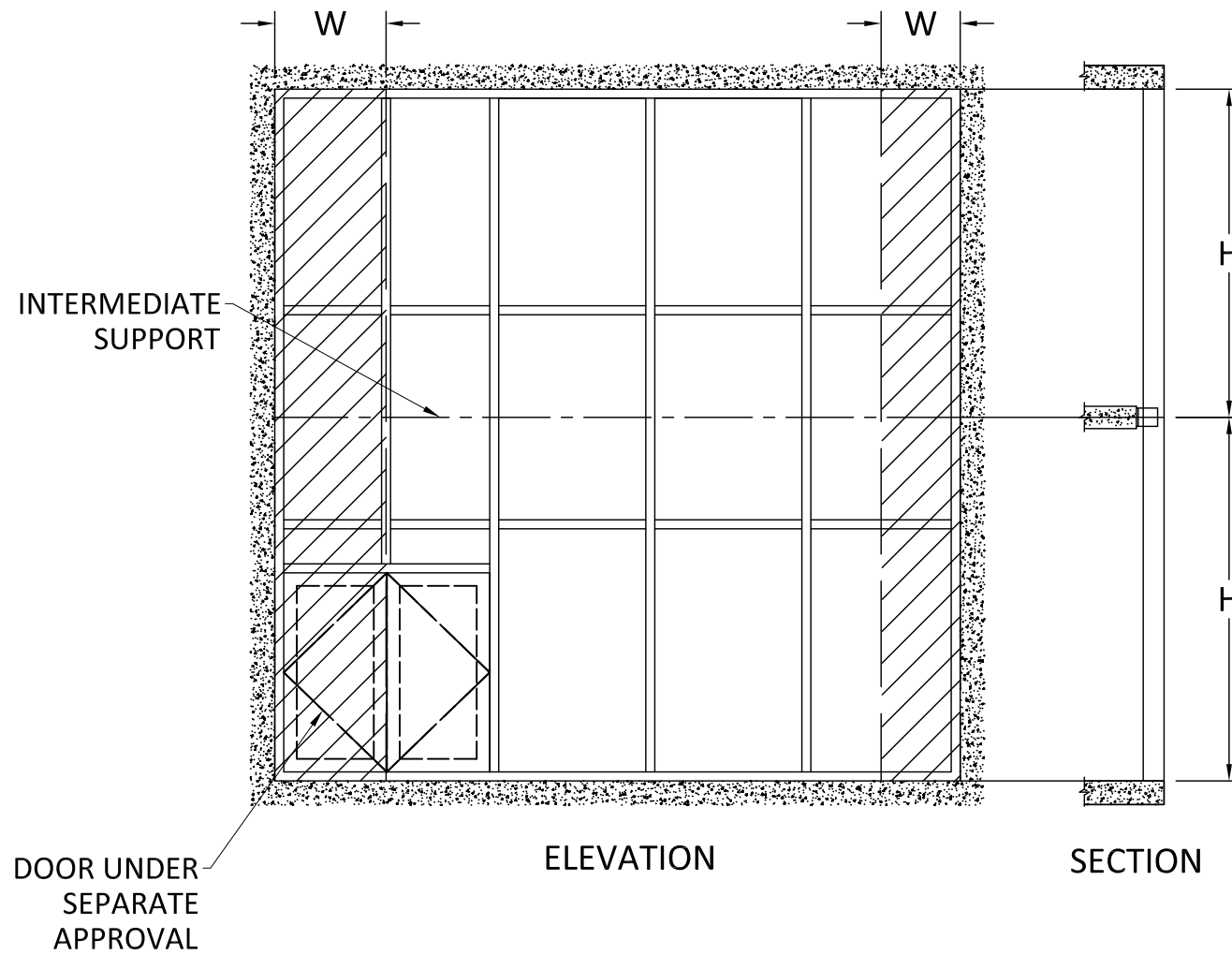

VERTICAL MEMBER TWIN SPAN NOTES:

- TABULATED DESIGN PRESSURE VALUES ARE BASED ON LIMITATIONS OF DEFLECTION, FIBERSTRESS, & END REACTION PER MULLION SPAN ('H') AND MULLION SPACING ('W').
- FOR SITE CONDITIONS WHICH EXCEED LIMITATIONS SHOWN, FURTHER ENGINEERING MAY BE REQUIRED ON A CASE BY CASE BASIS.
- FOR T, F ANCHORS AND INTERMEDIATE CONNECTION DETAILS, REFER TO SECTION 7 FOR ANCHOR SELECTION, SUBSTRATE REQUIREMENTS, AND FURTHER LIMITATIONS OF USE.

TUBELITE®
DEPENDABLE
LEADERS IN ECO-EFFICIENT STOREFRONT,
CURTAINWALL AND ENTRANCE SYSTEMS

3056 WALKER RIDGE DRIVE N.W.
WALKER, MICHIGAN 49544
PH: 800 866 2227 FX: 616 301 0008

TITLE: SERIES 400T CURTAIN WALL - SSG (NON-HVHZ) (NON-IMPACT)
VERTICAL SECTIONS
PREPARED BY: BUILDING DROPS, INC.
1900 NE MIAMI CT., STE. 2-15
MIAMI, FL 33132
PH: (954)399-8478
FAX: (954)744-4738
WEB: www.buildingdrops.com

REMARKS	BY	DATE

THE INSTALLATION DETAILS DESCRIBED HEREIN ARE GENERIC AND MAY NOT REFLECT ACTUAL CONDITIONS FOR A SPECIFIC SITE. IF SITE CONDITIONS CAUSE INSTALLATION TO DEVIATE FROM THE REQUIREMENTS DETAILED HEREIN, A LICENSED ENGINEER OR ARCHITECT SHALL PREPARE SITE SPECIFIC DOCUMENTS FOR USE WITH THIS DOCUMENT

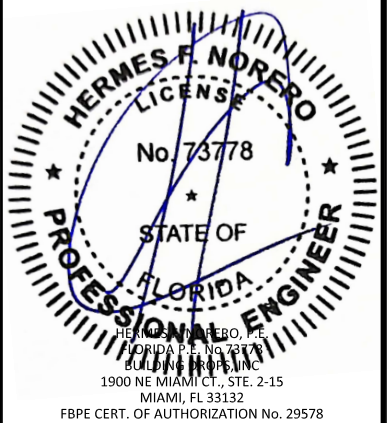

FL #: **FL27506**

DATE: **12.21.23**

DWG. BY: **MS** CHK. BY: **HFN**

SCALE: **NTS**

DWG. #: **TLI028**

SECTION
4.1
[PAGE 6 of 25]

12/28/2023 1:36 AM s:\projects\tubelite, inc\bc-23-1221 - fbc-submittal - f127506 400t series non-impact curtainwall revisions\dwg\TLI028.dwg

JAMB CAPACITY

TUBELITE®
DEPENDABLE
 LEADERS IN ECO-EFFICIENT STOREFRONT,
 CURTAINWALL AND ENTRANCE SYSTEMS

3056 WALKER RIDGE DRIVE N.W.
 WALKER, MICHIGAN 49544
 PH: 800 866 2227 FX: 616 301 0008

JAMB LOAD CAPACITY - TWIN SPAN 5"/5-1/2" SYSTEM (+/- PSF)		
NOMINAL DIMENSIONS		DESIGN PRESSURE
WIDTH 'W' (in)	SPAN HEIGHT 'H' (in)	EXT. (+) INT. (-)
12	90	100
15		100
18		100
21		88
24		77
27		69
30		62
12	96	100
15		100
18		96
21		83
24		72
27		64
30		58
12	102	100
15		100
18		91
21		78
24		68
27		61
30		54
12	108	100
15		100
18		86
21		73
24		64
27		57
30		51
12	114	100
15		97
18		81
21		70
24		61
27		54
30		49

JAMB LOAD CAPACITY - TWIN SPAN 5"/5-1/2" SYSTEM (+/- PSF)		
NOMINAL DIMENSIONS		DESIGN PRESSURE
WIDTH 'W' (in)	SPAN HEIGHT 'H' (in)	EXT. (+) INT. (-)
12	120	100
15		93
18		77
21		66
24		58
27		51
30		46
12	126	100
15		88
18		73
21		63
24		55
27		49
30		44
12	132	100
15		84
18		70
21		60
24		53
27		47
30		42
12	138	94
15		75
18		62
21		54
24		47
27		42
30		37
12	144	82
15		66
18		55
21		47
24		41
27		37
30		33

JAMB LOAD CAPACITY - TWIN SPAN 6"/7"/8" SYSTEM (+/- PSF)		
NOMINAL DIMENSIONS		DESIGN PRESSURE
WIDTH 'W' (in)	SPAN HEIGHT 'H' (in)	EXT. (+) INT. (-)
12	90	100
15		100
18		100
21		100
24		87
27		78
30		70
12	96	100
15		100
18		100
21		94
24		82
27		73
30		66
12	102	100
15		100
18		100
21		88
24		77
27		69
30		62
12	108	100
15		100
18		97
21		83
24		73
27		65
30		58
12	114	100
15		100
18		92
21		79
24		69
27		61
30		55

JAMB LOAD CAPACITY - TWIN SPAN 6"/7"/8" SYSTEM (+/- PSF)		
NOMINAL DIMENSIONS		DESIGN PRESSURE
WIDTH 'W' (in)	SPAN HEIGHT 'H' (in)	EXT. (+) INT. (-)
12	120	100
15		100
18		87
21		75
24		66
27		58
30		52
12	126	100
15		100
18		83
21		71
24		62
27		55
30		50
12	132	100
15		95
18		79
21		68
24		60
27		53
30		48
12	138	100
15		91
18		76
21		65
24		57
27		51
30		46
12	144	100
15		85
18		71
21		61
24		53
27		47
30		43

VERTICAL MEMBER TWIN SPAN NOTES:

- TABULATED DESIGN PRESSURE VALUES ARE BASED ON LIMITATIONS OF DEFLECTION, FIBERSTRESS, & END REACTION PER MULLION SPAN ('H') AND MULLION SPACING ('W').
- FOR SITE CONDITIONS WHICH EXCEED LIMITATIONS SHOWN, FURTHER ENGINEERING MAY BE REQUIRED ON A CASE BY CASE BASIS.
- FOR T, F ANCHORS AND INTERMEDIATE CONNECTION DETAILS, REFER TO SECTION 7 FOR ANCHOR SELECTION, SUBSTRATE REQUIREMENTS, AND FURTHER LIMITATIONS OF USE.

TITLE: SERIES 400T CURTAIN WALL - SSG (NON-HVHZ) (NON-IMPACT)
 VERTICAL SECTIONS
 PREPARED BY: BUILDING DROPS, INC.
 1900 NE MIAMI CT., STE. 2-15
 MIAMI, FL 33132
 PH: (954)399-8478
 FAX: (954)744-4738
 WEB: www.buildingdrops.com

REMARKS	BY	DATE

THE INSTALLATION DETAILS DESCRIBED HEREIN ARE GENERIC AND MAY NOT REFLECT ACTUAL CONDITIONS FOR A SPECIFIC SITE. IF SITE CONDITIONS CAUSE INSTALLATION TO DEVIATE FROM THE REQUIREMENTS DETAILED HEREIN, A LICENSED ENGINEER OR ARCHITECT SHALL PREPARE SITE SPECIFIC DOCUMENTS FOR USE WITH THIS DOCUMENT

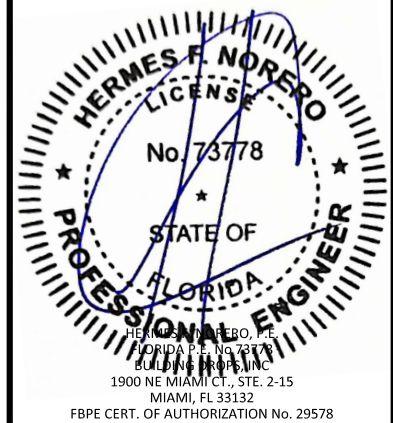

FL #: **FL27506**

DATE: **12.21.23**

DWG. BY: **MS** CHK. BY: **HFN**

SCALE: **NTS**

DWG. #: **TLI028**

SECTION
4.2
 [PAGE 7 of 25]

12/28/2023 1:36 AM s:\projects\tubelite, inc\lbc-23-1221 - fbc-submittal - f127506 400t series non-impact curtainwall revisions\dwgs\tli028.dwg

VERTICAL MULLION DETAILS

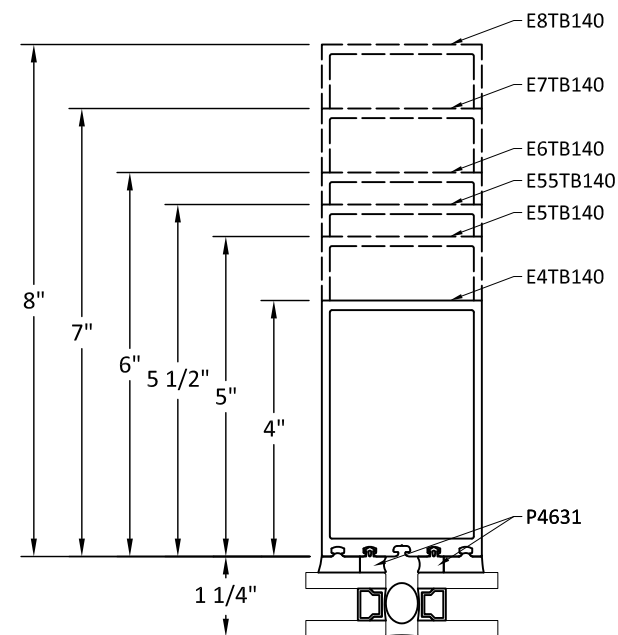

1
4.3 VERTICAL MULLION
STRUCTURAL SILICONE GLAZE

TUBELITE®
DEPENDABLE

LEADERS IN ECO-EFFICIENT STOREFRONT,
CURTAINWALL AND ENTRANCE SYSTEMS

3056 WALKER RIDGE DRIVE N.W.
WALKER, MICHIGAN 49544
PH: 800 866 2227 FX: 616 301 0008

TITLE:
SERIES 400T CURTAIN WALL - SSG
(NON-HVHZ) (NON-IMPACT)

VERTICAL SECTIONS

PREPARED BY:
BUILDING DROPS, INC.

1900 NE MIAMI CT., STE. 2-15
MIAMI, FL 33132
PH: (954)399-8478
FAX: (954)744-4738
WEB: www.buildingdrops.com



REMARKS	BY	DATE

THE INSTALLATION DETAILS DESCRIBED HEREIN ARE
GENERIC AND MAY NOT REFLECT ACTUAL CONDITIONS FOR
A SPECIFIC SITE. IF SITE CONDITIONS CAUSE INSTALLATION
TO DEVIATE FROM THE REQUIREMENTS DETAILED HEREIN, A
LICENSED ENGINEER OR ARCHITECT SHALL PREPARE SITE
SPECIFIC DOCUMENTS FOR USE WITH THIS DOCUMENT

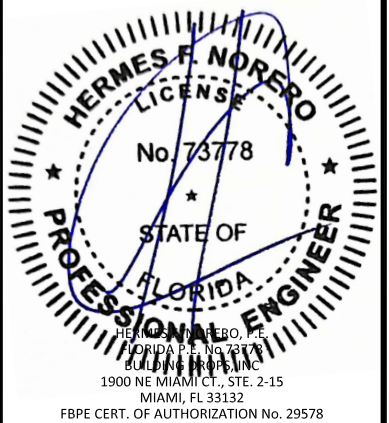

FL #: **FL27506**

DATE: **12.21.23**

DWG. BY: **MS** CHK. BY: **HFN**

SCALE: **NTS**

DWG. #: **TLI028**

SECTION
4.3
[PAGE 8 of 25]

12/28/2023 1:36 AM

s:\projects\tubelite, inc\bc-23-1221 - fbc submittal - f127506 400t series non-impact curtainwall revisions\dwgs\tli028.dwg

VERTICAL MULLION CAPACITY

MULLION LOAD CAPACITY - TWIN SPAN 4" SYSTEM (+/- PSF)		
NOMINAL DIMENSIONS		DESIGN PRESSURE
WIDTH 'W' (in)	SPAN HEIGHT 'H' (in)	EXT. (+) INT. (-)
24	90	100
30		100
36		84
42		72
48		63
54		56
60	51	33
24	96	100
30		95
36		79
42		68
48		59
54		53
60	47	29
24	102	100
30		89
36		74
42		64
48		56
54		50
60	45	25
24	108	100
30		84
36		70
42		60
48		53
54		47
60	42	22
24	114	97
30		78
36		65
42		56
48		49
54		43
60	39	

MULLION LOAD CAPACITY - TWIN SPAN 4" SYSTEM (+/- PSF)		
NOMINAL DIMENSIONS		DESIGN PRESSURE
WIDTH 'W' (in)	SPAN HEIGHT 'H' (in)	EXT. (+) INT. (-)
24	120	83
30		67
36		56
42		48
48		42
54		37
60	33	29
24	126	72
30		58
36		48
42		41
48		36
54		32
60	29	25
24	132	63
30		50
36		42
42		36
48		31
54		28
60	25	21
24	138	55
30		44
36		37
42		31
48		27
54		24
60	22	19
24	144	48
30		39
36		32
42		28
48		24
54		21
60	19	

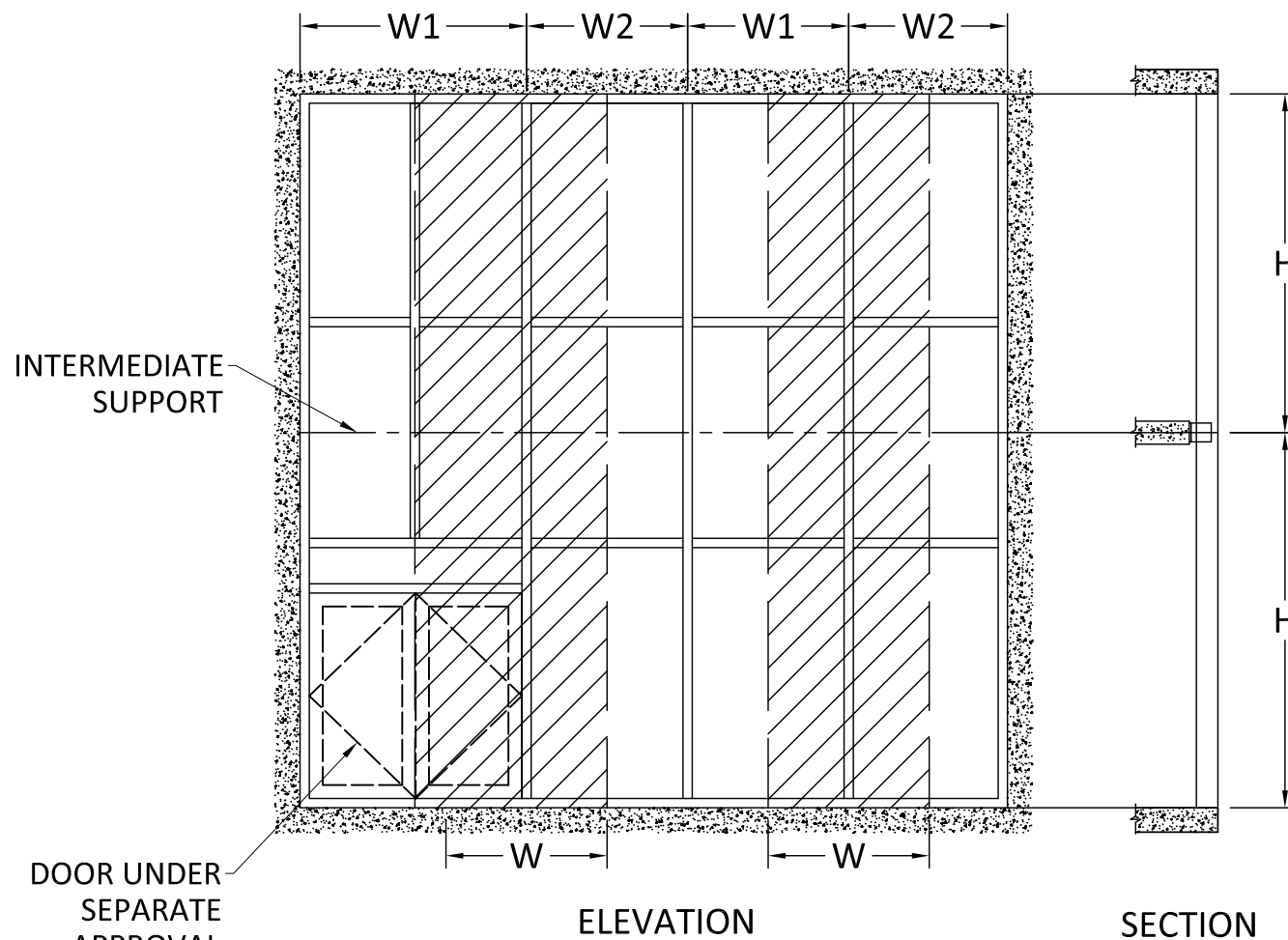

$$\text{WIDTH (W)} = \frac{W1 + W2}{2}$$

VERTICAL MEMBER TWIN SPAN NOTES:

- TABULATED DESIGN PRESSURE VALUES ARE BASED ON LIMITATIONS OF DEFLECTION, FIBERSTRESS, & END REACTION PER MULLION SPAN ('H') AND MULLION SPACING ('W').
- FOR SITE CONDITIONS WHICH EXCEED LIMITATIONS SHOWN, FURTHER ENGINEERING MAY BE REQUIRED ON A CASE BY CASE BASIS.
- FOR T, F ANCHORS AND INTERMEDIATE CONNECTION DETAILS, REFER TO SECTION 7 FOR ANCHOR SELECTION, SUBSTRATE REQUIREMENTS, AND FURTHER LIMITATIONS OF USE.

TUBELITE
DEPENDABLE
LEADERS IN ECO-EFFICIENT STOREFRONT,
CURTAINWALL AND ENTRANCE SYSTEMS

3056 WALKER RIDGE DRIVE N.W.
WALKER, MICHIGAN 49544
PH: 800 866 2227 FX: 616 301 0008

TITLE:
SERIES 400T CURTAIN WALL - SSG
(NON-HVHZ) (NON-IMPACT)

VERTICAL SECTIONS

PREPARED BY:
BUILDING DROPS, INC.
1900 NE MIAMI CT., STE. 2-15
MIAMI, FL 33132
PH: (954)399-8478
FAX: (954)744-4738
WEB: www.buildingdrops.com



REMARKS	BY	DATE

THE INSTALLATION DETAILS DESCRIBED HEREIN ARE GENERIC AND MAY NOT REFLECT ACTUAL CONDITIONS FOR A SPECIFIC SITE. IF SITE CONDITIONS CAUSE INSTALLATION TO DEVIATE FROM THE REQUIREMENTS DETAILED HEREIN, A LICENSED ENGINEER OR ARCHITECT SHALL PREPARE SITE SPECIFIC DOCUMENTS FOR USE WITH THIS DOCUMENT

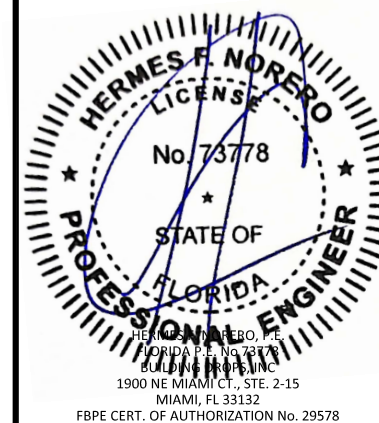

FL #:
FL27506

DATE: **12.21.23**

DWG. BY: **MS** CHK. BY: **HFN**

SCALE: **NTS**

DWG. #: **TLI028**

SECTION

4.4

12/28/2023 1:36 AM s:\projects\tubelite, inc\lbc-23-1221 - fbc-submittal - f127506 400t series non-impact curtainwall revisions\dwg\lbc28.dwg

VERTICAL MULLION CAPACITY

MULLION LOAD CAPACITY - TWIN SPAN 5"/5-1/2" SYSTEM (+/- PSF)		
NOMINAL DIMENSIONS		DESIGN PRESSURE
WIDTH 'W' (in)	SPAN HEIGHT 'H' (in)	EXT. (+) INT. (-)
24	90	100
30		100
36		100
42		88
48		77
54		69
60		62
24	96	100
30		100
36		96
42		83
48		72
54		64
60		58
24	102	100
30		100
36		91
42		78
48		68
54		61
60		54
24	108	100
30		100
36		86
42		73
48		64
54		57
60		51
24	114	100
30		97
36		81
42		70
48		61
54		54
60		49

MULLION LOAD CAPACITY - TWIN SPAN 5"/5-1/2" SYSTEM (+/- PSF)		
NOMINAL DIMENSIONS		DESIGN PRESSURE
WIDTH 'W' (in)	SPAN HEIGHT 'H' (in)	EXT. (+) INT. (-)
24	120	100
30		93
36		77
42		66
48		58
54		51
60		46
24	126	100
30		88
36		73
42		63
48		55
54		49
60		44
24	132	100
30		84
36		70
42		60
48		53
54		47
60		42
24	138	94
30		75
36		62
42		54
48		47
54		42
60		37
24	144	82
30		66
36		55
42		47
48		41
54		37
60		33

MULLION LOAD CAPACITY - TWIN SPAN 6"/7"/8" SYSTEM (+/- PSF)		
NOMINAL DIMENSIONS		DESIGN PRESSURE
WIDTH 'W' (in)	SPAN HEIGHT 'H' (in)	EXT. (+) INT. (-)
24	90	100
30		100
36		100
42		100
48		87
54		78
60		70
24	96	100
30		100
36		100
42		94
48		82
54		73
60		66
24	102	100
30		100
36		100
42		88
48		77
54		69
60		62
24	108	100
30		100
36		97
42		83
48		73
54		65
60		58
24	114	100
30		100
36		92
42		79
48		69
54		61
60		55

MULLION LOAD CAPACITY - TWIN SPAN 6"/7"/8" SYSTEM (+/- PSF)		
NOMINAL DIMENSIONS		DESIGN PRESSURE
WIDTH 'W' (in)	SPAN HEIGHT 'H' (in)	EXT. (+) INT. (-)
24	120	100
30		100
36		87
42		75
48		66
54		58
60		52
24	126	100
30		100
36		83
42		71
48		62
54		55
60		50
24	132	100
30		95
36		79
42		68
48		60
54		53
60		48
24	138	100
30		91
36		76
42		65
48		57
54		51
60		46
24	144	100
30		85
36		71
42		61
48		53
54		47
60		43

VERTICAL MEMBER TWIN SPAN NOTES:

- TABULATED DESIGN PRESSURE VALUES ARE BASED ON LIMITATIONS OF DEFLECTION, FIBERSTRESS, & END REACTION PER MULLION SPAN ('H') AND MULLION SPACING ('W').
- FOR SITE CONDITIONS WHICH EXCEED LIMITATIONS SHOWN, FURTHER ENGINEERING MAY BE REQUIRED ON A CASE BY CASE BASIS.
- FOR T, F ANCHORS AND INTERMEDIATE CONNECTION DETAILS, REFER TO SECTION 7 FOR ANCHOR SELECTION, SUBSTRATE REQUIREMENTS, AND FURTHER LIMITATIONS OF USE.



3056 WALKER RIDGE DRIVE N.W.
WALKER, MICHIGAN 49544
PH: 800 866 2227 FX: 616 301 0008

TITLE:
SERIES 400T CURTAIN WALL - SSG
(NON-HVHZ) (NON-IMPACT)

VERTICAL SECTIONS

PREPARED BY:
BUILDING DROPS, INC.
1900 NE MIAMI CT., STE. 2-15
MIAMI, FL 33132

PH: (954) 399-8478
FAX: (954) 744-4738
WEB: www.buildingdrops.com



REMARKS	BY	DATE

THE INSTALLATION DETAILS DESCRIBED HEREIN ARE GENERIC AND MAY NOT REFLECT ACTUAL CONDITIONS FOR A SPECIFIC SITE. IF SITE CONDITIONS CAUSE INSTALLATION TO DEVIATE FROM THE REQUIREMENTS DETAILED HEREIN, A LICENSED ENGINEER OR ARCHITECT SHALL PREPARE SITE SPECIFIC DOCUMENTS FOR USE WITH THIS DOCUMENT

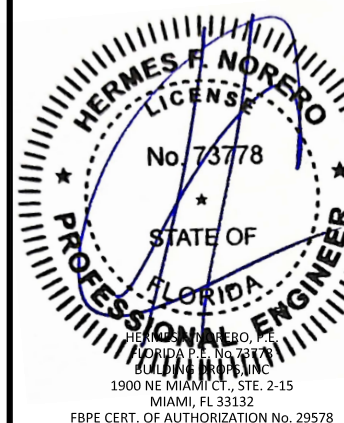

FL #:
FL27506

DATE: **12.21.23**

DWG. BY: **MS** CHK. BY: **HFN**

SCALE: **NTS**

DWG. #: **TLI028**

SECTION
4.5
[PAGE 10 of 25]

12/28/2023 1:36 AM s:\projects\tubelite, inc\lbc-23-1221 - fbc submittal - f127506 400t series non-impact curtainwall revisions\dwgs\tli028.dwg

CORNER DETAILS

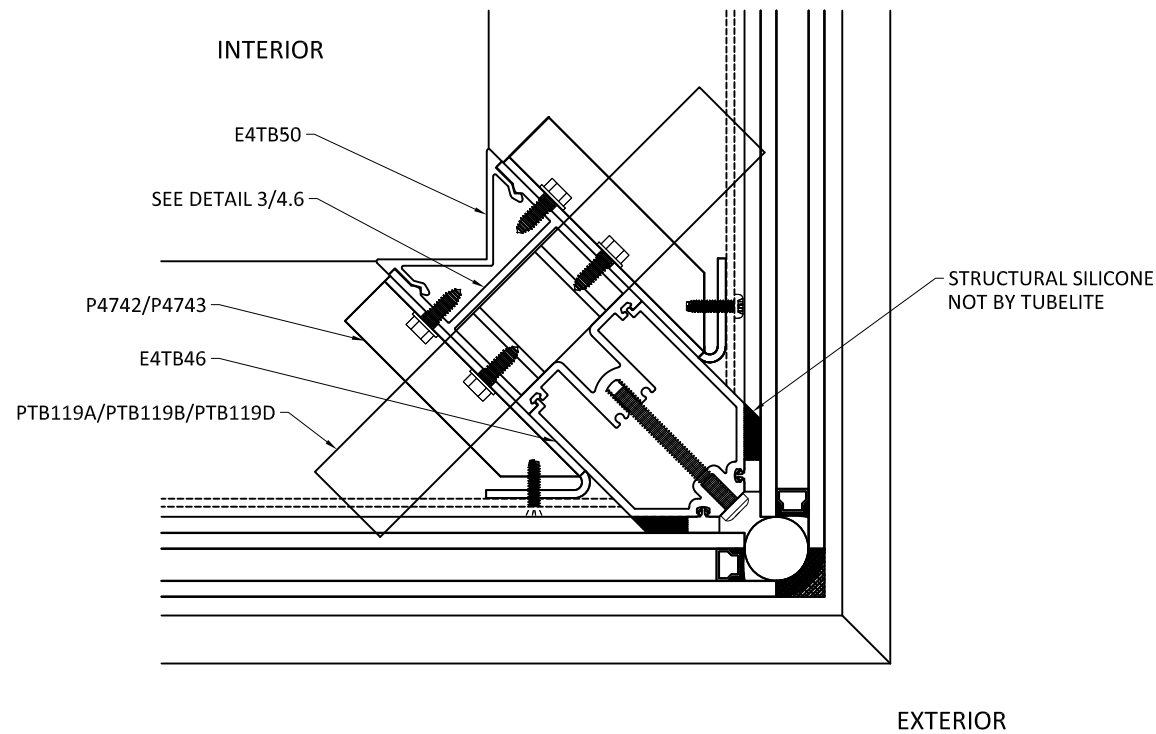

1
4.6 **OUTSIDE CORNER**
STRUCTURAL SILICONE GLAZE

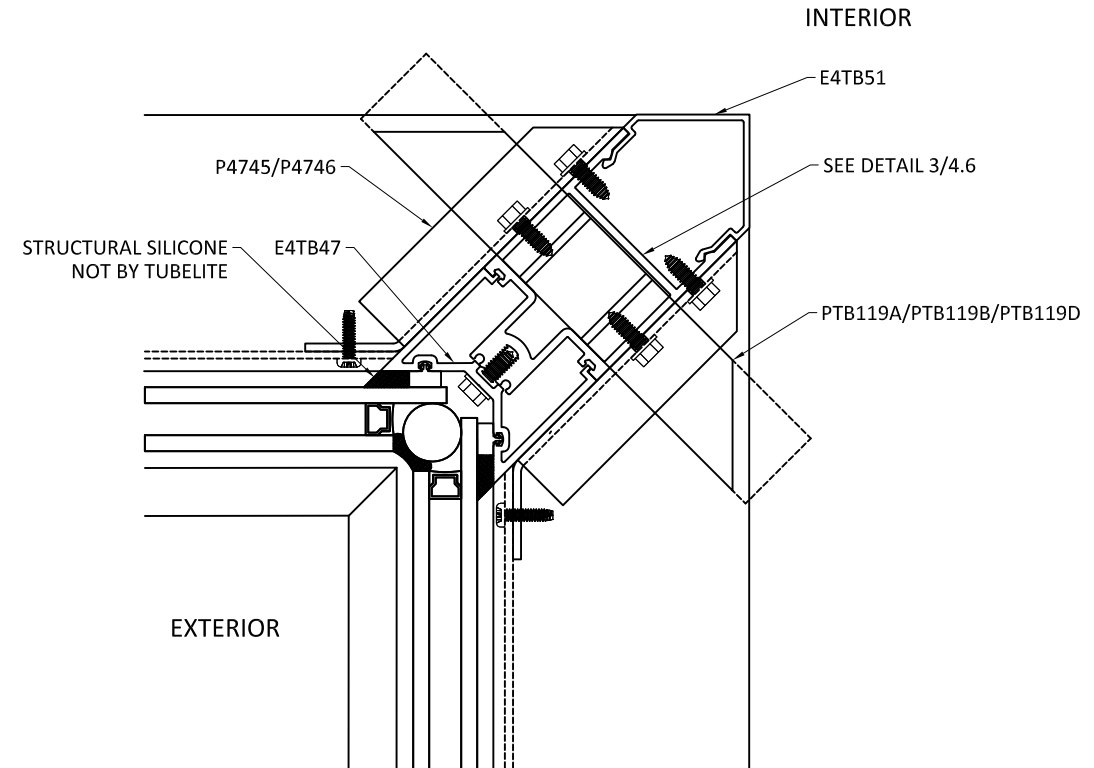

2
4.6 **INSIDE CORNER**
STRUCTURAL SILICONE GLAZE

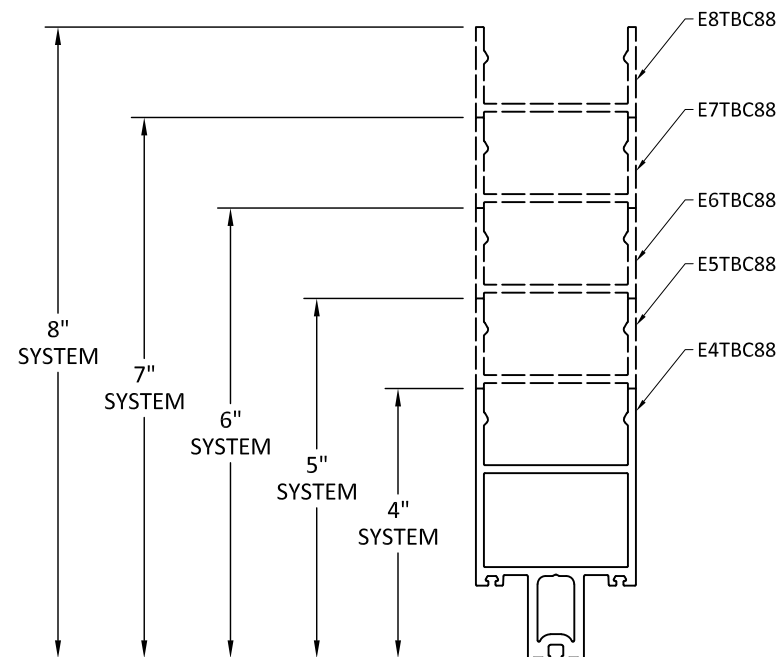

3
4.6 **CORNER PROFILES**

TUBELITE
DEPENDABLE

LEADERS IN ECO-EFFICIENT STOREFRONT,
CURTAINWALL AND ENTRANCE SYSTEMS

3056 WALKER RIDGE DRIVE N.W.
WALKER, MICHIGAN 49544
PH: 800 866 2227 FX: 616 301 0008

TITLE:
SERIES 400T CURTAIN WALL - SSG
(NON-HVHZ) (NON-IMPACT)

VERTICAL SECTIONS

PREPARED BY:
BUILDING DROPS, INC.

1900 NE MIAMI CT., STE. 2-15
MIAMI, FL 33132
PH: (954)399-8478
FAX: (954)744-4738
WEB: www.buildingdrops.com



REMARKS	BY	DATE

THE INSTALLATION DETAILS DESCRIBED HEREIN ARE
GENERIC AND MAY NOT REFLECT ACTUAL CONDITIONS FOR
A SPECIFIC SITE. IF SITE CONDITIONS CAUSE INSTALLATION
TO DEVIATE FROM THE REQUIREMENTS DETAILED HEREIN, A
LICENSED ENGINEER OR ARCHITECT SHALL PREPARE SITE
SPECIFIC DOCUMENTS FOR USE WITH THIS DOCUMENT

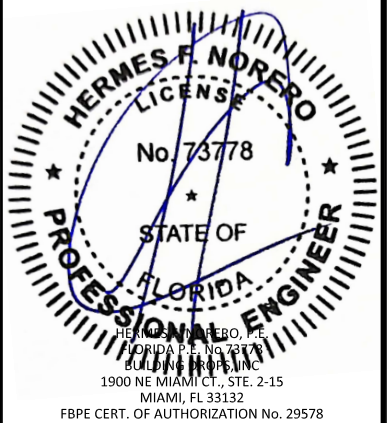

FL #:
FL27506

DATE: **12.21.23**

DWG. BY: **MS** CHK. BY: **HFN**

SCALE: **NTS**

DWG. #: **TLI028**

SECTION

4.6

12/28/2023 1:36 AM s:\projects\tubelite, inc\lbc-23-1221 - fbc submittal - f127506 400t series non-impact curtainwall revisions\dwgs\tli028.dwg

CORNER MULLION CAPACITY

CORNER LOAD CAPACITY - TWIN SPAN 4" SYSTEM (+/- PSF)		
NOMINAL DIMENSIONS		DESIGN PRESSURE
MAX. WIDTH 'W' (in)	SPAN HEIGHT 'H' (in)	EXT. (+) INT. (-)
24	90	100
30		99
36		83
42		71
48		62
54		55
60	50	22
24	96	100
30		87
36		73
42		62
48		55
54		49
60	44	19
24	102	92
30		73
36		61
42		52
48		46
54		41
60	37	17
24	108	77
30		62
36		51
42		44
48		39
54		34
60	31	15
24	114	66
30		52
36		44
42		37
48		33
54		29
60	26	13

CORNER LOAD CAPACITY - TWIN SPAN 4" SYSTEM (+/- PSF)		
NOMINAL DIMENSIONS		DESIGN PRESSURE
MAX. WIDTH 'W' (in)	SPAN HEIGHT 'H' (in)	EXT. (+) INT. (-)
24	120	56
30		45
36		37
42		32
48		28
54		25
60	22	19
24	126	49
30		39
36		32
42		28
48		24
54		22
60	19	17
24	132	42
30		34
36		28
42		24
48		21
54		19
60	17	15
24	138	37
30		30
36		25
42		21
48		18
54		16
60	15	13
24	144	33
30		26
36		22
42		19
48		16
54		14
60	13	13

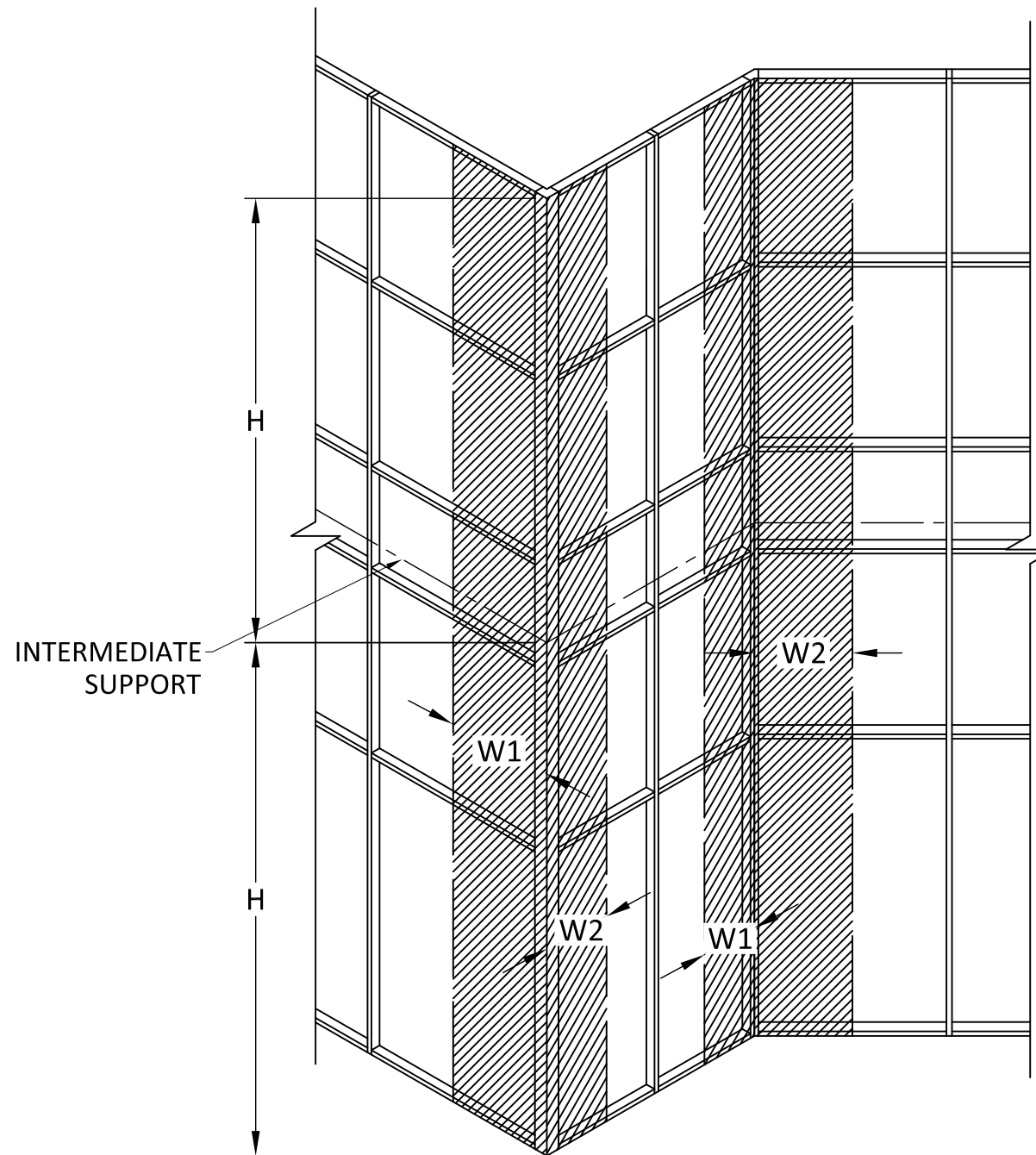

WIDTH (W) = W1 + W2

CORNER TRIBUTARY AREAS ISOMETRIC

VERTICAL MEMBER TWIN SPAN NOTES:

- TABULATED DESIGN PRESSURE VALUES ARE BASED ON LIMITATIONS OF DEFLECTION, FIBERSTRESS, & END REACTION PER MULLION SPAN ('H') AND MULLION SPACING ('W').
- FOR SITE CONDITIONS WHICH EXCEED LIMITATIONS SHOWN, FURTHER ENGINEERING MAY BE REQUIRED ON A CASE BY CASE BASIS.
- FOR T, F ANCHORS AND INTERMEDIATE CONNECTION DETAILS, REFER TO SECTION 7 FOR ANCHOR SELECTION, SUBSTRATE REQUIREMENTS, AND FURTHER LIMITATIONS OF USE.

TUBELITE®
DEPENDABLE
LEADERS IN ECO-EFFICIENT STOREFRONT,
CURTAINWALL AND ENTRANCE SYSTEMS

3056 WALKER RIDGE DRIVE N.W.
WALKER, MICHIGAN 49544
PH: 800 866 2227 FX: 616 301 0008

TITLE: SERIES 400T CURTAIN WALL - SSG (NON-HVHZ) (NON-IMPACT)
VERTICAL SECTIONS
PREPARED BY: BUILDING DROPS, INC.
1900 NE MIAMI CT., STE. 2-15
MIAMI, FL 33132
PH: (954)399-8478
FAX: (954)744-4738
WEB: www.buildingdrops.com

REMARKS	BY	DATE

THE INSTALLATION DETAILS DESCRIBED HEREIN ARE GENERIC AND MAY NOT REFLECT ACTUAL CONDITIONS FOR A SPECIFIC SITE. IF SITE CONDITIONS CAUSE INSTALLATION TO DEVIATE FROM THE REQUIREMENTS DETAILED HEREIN, A LICENSED ENGINEER OR ARCHITECT SHALL PREPARE SITE SPECIFIC DOCUMENTS FOR USE WITH THIS DOCUMENT

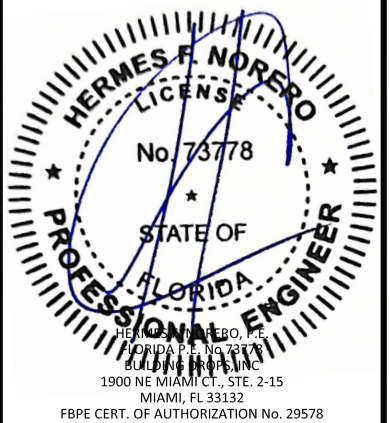

FL #: **FL27506**

DATE: **12.21.23**

DWG. BY: **MS** CHK. BY: **HFN**

SCALE: **NTS**

DWG. #: **TLI028**

SECTION
4.7
[PAGE 12 of 25]

12/28/2023 1:36 AM s:\projects\tubelite, inc\lbc-23-1221 - fbc-submittal - f127506 400t series non-impact curtainwall revisions\dwg\lbc28.dwg

CORNER MULLION CAPACITY

CORNER LOAD CAPACITY - TWIN SPAN 5" SYSTEM (+/- PSF)		
NOMINAL DIMENSIONS		DESIGN PRESSURE
MAX. WIDTH 'W' (in)	SPAN HEIGHT 'H' (in)	EXT. (+) INT. (-)
24	90	100
30		100
36		100
42		94
48		83
54		73
60	66	
24	96	100
30		100
36		100
42		89
48		77
54		69
60	62	
24	102	100
30		100
36		97
42		83
48		73
54		65
60	58	
24	108	100
30		100
36		88
42		76
48		66
54		59
60	53	
24	114	100
30		90
36		75
42		64
48		56
54		50
60	45	

CORNER LOAD CAPACITY - TWIN SPAN 5" SYSTEM (+/- PSF)		
NOMINAL DIMENSIONS		DESIGN PRESSURE
MAX. WIDTH 'W' (in)	SPAN HEIGHT 'H' (in)	EXT. (+) INT. (-)
24	120	97
30		77
36		64
42		55
48		48
54		43
60	39	
24	126	84
30		67
36		56
42		48
48		42
54		37
60	33	
24	132	73
30		58
36		48
42		42
48		36
54		32
60	29	
24	138	64
30		51
36		42
42		36
48		32
54		28
60	25	
24	144	56
30		45
36		37
42		32
48		28
54		25
60	22	

CORNER LOAD CAPACITY - TWIN SPAN 6"/7"/8" SYSTEM (+/- PSF)		
NOMINAL DIMENSIONS		DESIGN PRESSURE
MAX. WIDTH 'W' (in)	SPAN HEIGHT 'H' (in)	EXT. (+) INT. (-)
24	90	100
30		100
36		100
42		100
48		90
54		80
60	72	
24	96	100
30		100
36		100
42		97
48		85
54		75
60	68	
24	102	100
30		100
36		100
42		91
48		80
54		71
60	64	
24	108	100
30		100
36		100
42		86
48		75
54		67
60	60	
24	114	100
30		100
36		95
42		82
48		71
54		63
60	57	

CORNER LOAD CAPACITY - TWIN SPAN 6"/7"/8" SYSTEM (+/- PSF)		
NOMINAL DIMENSIONS		DESIGN PRESSURE
MAX. WIDTH 'W' (in)	SPAN HEIGHT 'H' (in)	EXT. (+) INT. (-)
24	120	100
30		100
36		90
42		77
48		68
54		60
60	54	
24	126	100
30		100
36		86
42		74
48		65
54		57
60	52	
24	132	100
30		95
36		79
42		68
48		59
54		53
60	48	
24	138	100
30		83
36		69
42		59
48		52
54		46
60	42	
24	144	92
30		73
36		61
42		52
48		46
54		41
60	37	

VERTICAL MEMBER TWIN SPAN NOTES:

- TABULATED DESIGN PRESSURE VALUES ARE BASED ON LIMITATIONS OF DEFLECTION, FIBERSTRESS, & END REACTION PER MULLION SPAN ('H') AND MULLION SPACING ('W').
- FOR SITE CONDITIONS WHICH EXCEED LIMITATIONS SHOWN, FURTHER ENGINEERING MAY BE REQUIRED ON A CASE BY CASE BASIS.
- FOR T, F ANCHORS AND INTERMEDIATE CONNECTION DETAILS, REFER TO SECTION 7 FOR ANCHOR SELECTION, SUBSTRATE REQUIREMENTS, AND FURTHER LIMITATIONS OF USE.

TUBELITE®
DEPENDABLE

LEADERS IN ECO-EFFICIENT STOREFRONT, CURTAINWALL AND ENTRANCE SYSTEMS

3056 WALKER RIDGE DRIVE N.W.
WALKER, MICHIGAN 49544
PH: 800 866 2227 FX: 616 301 0008

TITLE: SERIES 400T CURTAIN WALL - SSG (NON-HVHZ) (NON-IMPACT)

VERTICAL SECTIONS

PREPARED BY: BUILDING DROPS, INC.
1900 NE MIAMI CT., STE. 2-15
MIAMI, FL 33132
PH: (954) 399-8478
FAX: (954) 744-4738
WEB: www.buildingdrops.com



REMARKS	BY	DATE

THE INSTALLATION DETAILS DESCRIBED HEREIN ARE GENERIC AND MAY NOT REFLECT ACTUAL CONDITIONS FOR A SPECIFIC SITE. IF SITE CONDITIONS CAUSE INSTALLATION TO DEVIATE FROM THE REQUIREMENTS DETAILED HEREIN, A LICENSED ENGINEER OR ARCHITECT SHALL PREPARE SITE SPECIFIC DOCUMENTS FOR USE WITH THIS DOCUMENT

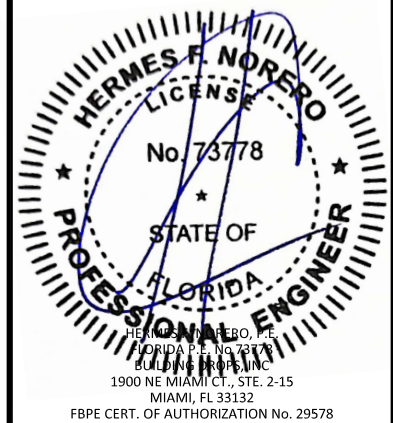

FL #: **FL27506**

DATE: **12.21.23**

DWG. BY: **MS** CHK. BY: **HFN**

SCALE: **NTS**

DWG. #: **TLI028**

SECTION
4.8
[PAGE 13 of 25]

12/28/2023 1:36 AM s:\projects\tubelite, inc\lbc-23-1221 - fbc-submittal - f127506 400t series non-impact curtainwall revisions\dwgs\tli028.dwg

DOOR SECTION DETAILS

TUBELITE
DEPENDABLE
LEADERS IN ECO-EFFICIENT STOREFRONT,
CURTAINWALL AND ENTRANCE SYSTEMS

3056 WALKER RIDGE DRIVE N.W.
WALKER, MICHIGAN 49544
PH: 800 866 2227 FX: 616 301 0008

HORIZONTAL TRANSOM DESIGN VALUES						
WIDTH 'W' (in)	4" SYSTEM		5" SYSTEM		6"/7"/8" SYSTEM	
	MAX. DLO HEIGHT 'H' (in)	DESIGN PRESSURE (+/- PSF)	MAX. DLO HEIGHT 'H' (in)	DESIGN PRESSURE (+/- PSF)	MAX. DLO HEIGHT 'H' (in)	DESIGN PRESSURE (+/- PSF)
72	22	76	22	93	22	100
78	20	71	22	86	22	97
84	18	67	22	79	22	90
90	16	59	21	74	22	84
96	14	53	19	67	22	79

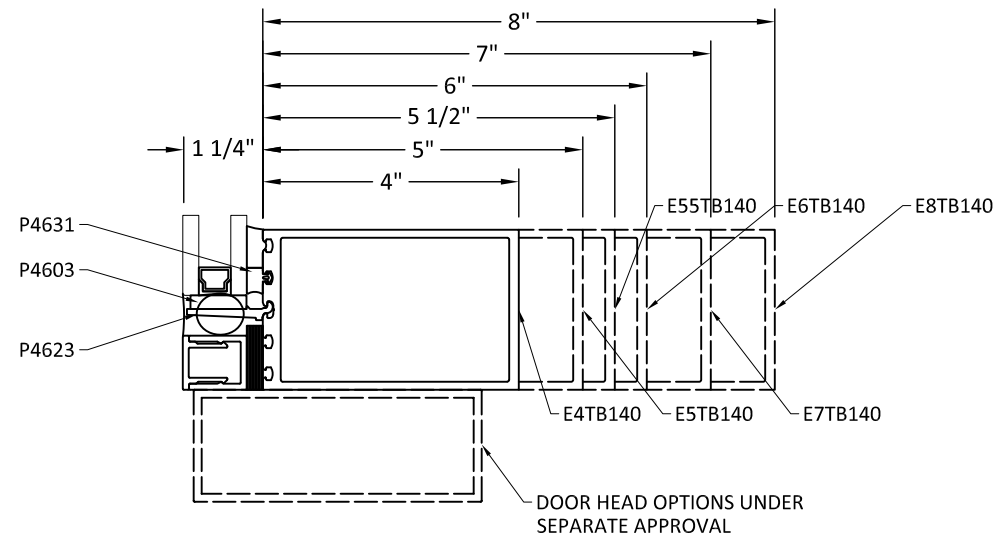
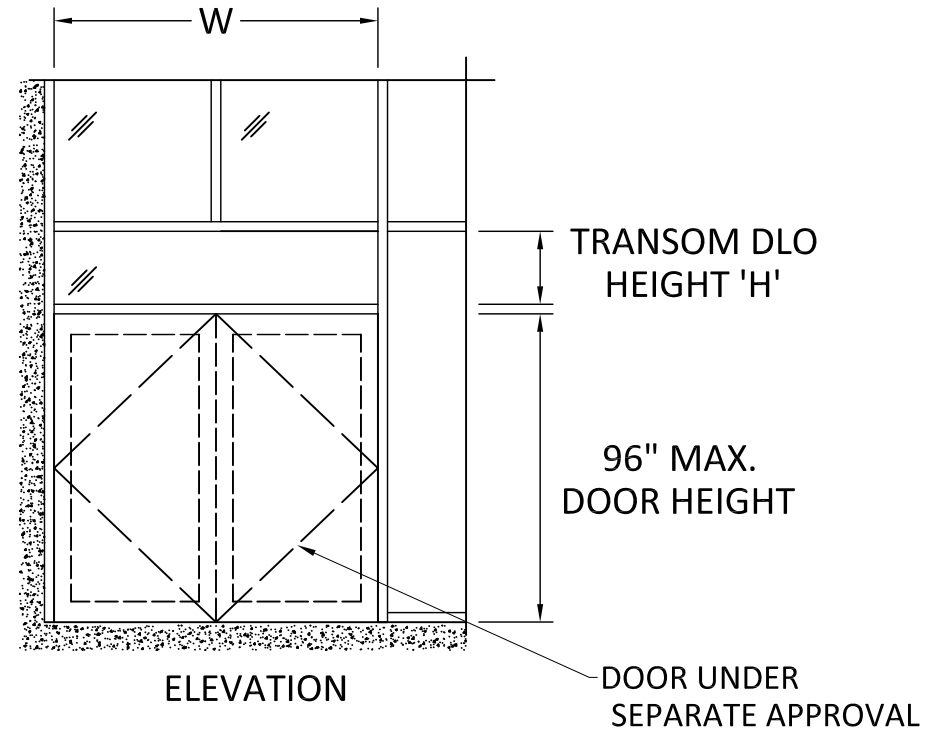

1
5.0

DOOR HEAD
WITH TRANSOM

TITLE:
SERIES 400T CURTAIN WALL - SSG
(NON-HVHZ) (NON-IMPACT)

DOOR SECTION DETAILS

PREPARED BY:
BUILDING DROPS, INC.
1900 NE MIAMI CT., STE. 2-15
MIAMI, FL 33132
PH: (954)399-8478
FAX: (954)744-4738
WEB: www.buildingdrops.com

REMARKS	BY	DATE

THE INSTALLATION DETAILS DESCRIBED HEREIN ARE
GENERIC AND MAY NOT REFLECT ACTUAL CONDITIONS FOR
A SPECIFIC SITE. IF SITE CONDITIONS CAUSE INSTALLATION
TO DEVIATE FROM THE REQUIREMENTS DETAILED HEREIN, A
LICENSED ENGINEER OR ARCHITECT SHALL PREPARE SITE
SPECIFIC DOCUMENTS FOR USE WITH THIS DOCUMENT

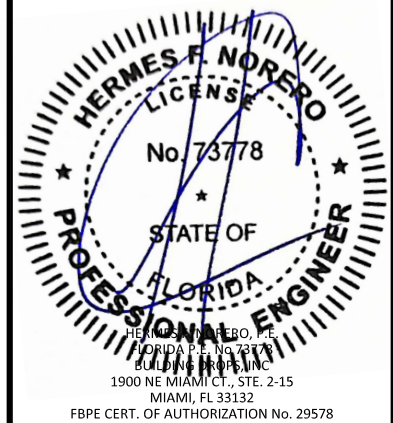

FL #:
FL27506

DATE: **12.21.23**

DWG. BY: **MS** CHK. BY: **HFN**

SCALE: **NTS**

DWG. #: **TLI028**

SECTION
5.0
[PAGE 14 of 25]

s:\projects\tubelite, inc\lbc-23-1221 - fbc submittal - f127506 400t series non-impact curtainwall revisions\dwgs\tli028.dwg 12/28/2023 1:36 AM

GLAZING DETAILS AND CAPACITY

TUBELITE
DEPENDABLE
LEADERS IN ECO-EFFICIENT STOREFRONT,
CURTAINWALL AND ENTRANCE SYSTEMS

3056 WALKER RIDGE DRIVE N.W.
WALKER, MICHIGAN 49544
PH: 800 866 2227 FX: 616 301 0008

TITLE:
SERIES 400T CURTAIN WALL - SSG
(NON-HVHZ) (NON-IMPACT)

GLAZING DETAILS

PREPARED BY:
BUILDING DROPS, INC.
1900 NE MIAMI CT., STE. 2-15
MIAMI, FL 33132
PH: (954)399-8478
FAX: (954)744-4738
WEB: www.buildingdrops.com

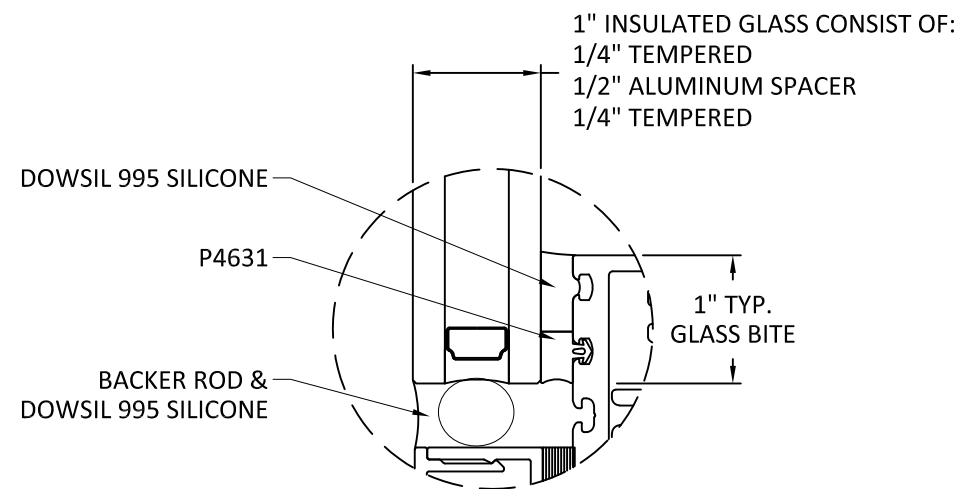

GLAZING DETAILS

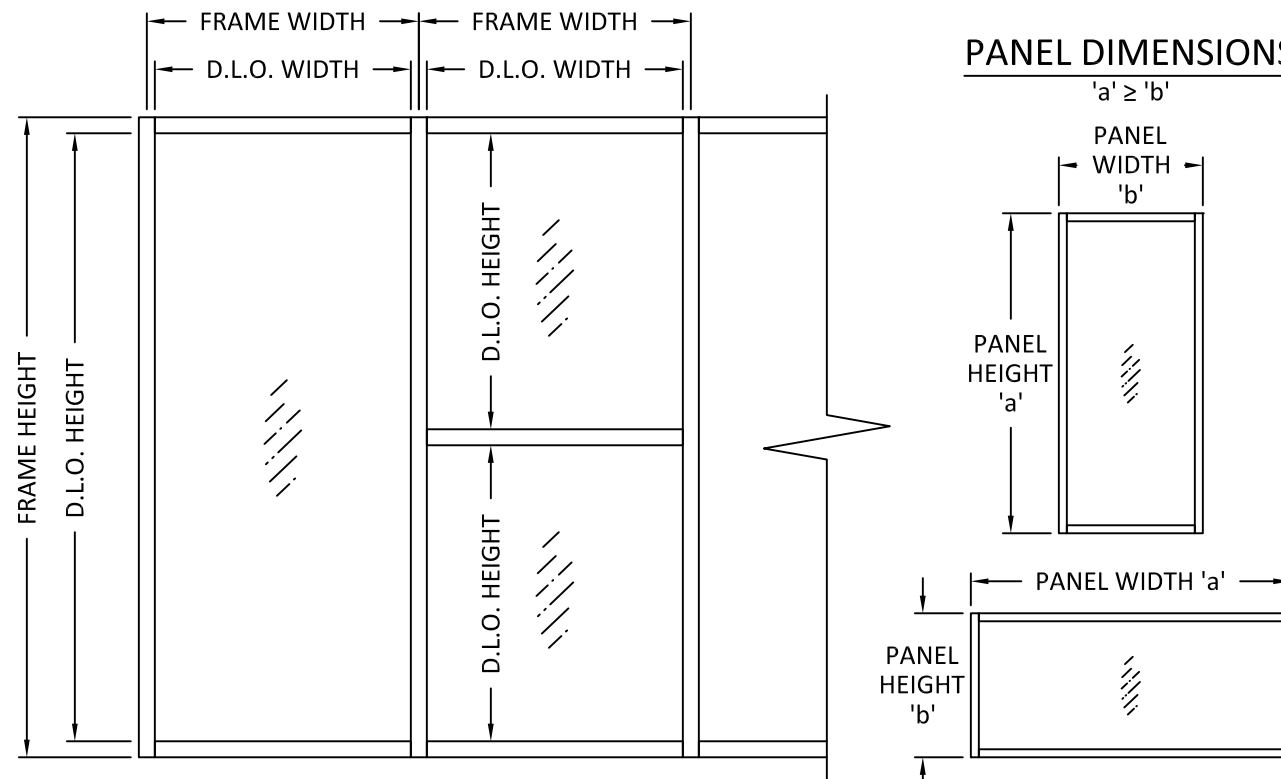

D.L.O. WIDTH = FRAME WIDTH - 2.5"
D.L.O. HEIGHT = FRAME HEIGHT - 5"

GLAZING NOTES:

- GLASS TYPE & THICKNESS COMPLIES WITH ASTM E1300 REQUIREMENTS AS WELL AS APPLICABLE SAFETY GLAZING REQUIREMENTS PER THE FBC. TEMPER AND SAFETY GLAZING REQUIREMENTS SHALL BE REVIEWED ON A SITE SPECIFIC BASIS.
- SETTING BLOCK DUROMETER HARDNESS OF 70-90 (SHORE A) AS REFERENCED IN FBC CHAPTER 24.
- SETTING BLOCKS TO BE LOCATED AT 1/4 SPAN LENGTH FOR GLASS WIDER THAN 36" AS PER FBC CHAPTER 24.
- D.L.O. AND DESIGN PRESSURES MAY NOT EXCEED MAX VALUES IN DESIGN PRESSURE TABLES.

THE INSTALLATION DETAILS DESCRIBED HEREIN ARE GENERIC AND MAY NOT REFLECT ACTUAL CONDITIONS FOR A SPECIFIC SITE. IF SITE CONDITIONS CAUSE INSTALLATION TO DEVIATE FROM THE REQUIREMENTS DETAILED HEREIN, A LICENSED ENGINEER OR ARCHITECT SHALL PREPARE SITE SPECIFIC DOCUMENTS FOR USE WITH THIS DOCUMENT

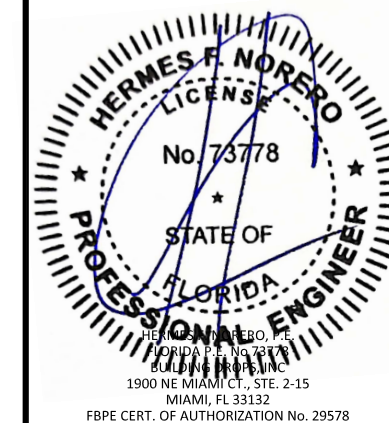

FL #:
FL27506

DATE: **12.21.23**

DWG. BY:
MS

CHK. BY:
HFN

SCALE: **NTS**

DWG. #: **TLI028**

SECTION

6.0

s:\projects\tubelite, inc\lbc-23-1221 - fbc submittal - f127506 400t series non-impact curtainwall revisions\dwgs\tli028.dwg 12/28/2023 1:37 AM

GLAZING DETAILS AND CAPACITY

GLASS LOAD CAPACITY (PSF)		
DAYLIGHT OPENING DIMS. (in)		STRUCTURAL SILICONE GLAZE
D.L.O. WIDTH	D.L.O. HEIGHT	EXT. (+) INT. (-)
36	36	60
42		60
48		50
54		42
60		36
66		32
72		28
78		25
84		23
90		21
36	42	60
42		55
48		56
54		46
60		39
66		34
72		30
78		27
84		24
90		22
36	48	60
42		55
48		48
54		50
60		42
66		36
72		32
78		28
84		25
90		23
36	54	60
42		55
48		48
54		43
60		46
66		39
72		34
78		30
84		27

GLASS LOAD CAPACITY (PSF)		
DAYLIGHT OPENING DIMS. (in)		STRUCTURAL SILICONE GLAZE
D.L.O. WIDTH	D.L.O. HEIGHT	EXT. (+) INT. (-)
36	60	60
42		55
48		48
54		43
60		38
66		42
72		36
78		32
84		28
90		25
36	66	58
42		53
48		48
54		43
60		38
66		35
72		38
78		35
84		32
90		29
36	72	56
42		51
48		47
54		43
60		38
66		35
72		32
78		29
84		26
90		23
36	78	55
42		49
48		46
54		43
60		38
66		35
72		32
78		29
84		26
90		23
36	84	53
42		47
48		43
54		39
60		35
66		32
72		29
78		26
84		23
90		20
36	90	52
42		46
48		42
54		38
60		34
66		30
72		27
78		24
84		21
90		18
36	96	51
42		45
48		41
54		37
60		33
66		29
72		26
78		23
84		20
90		17
36	102	50
42		44
48		40
54		36
60		32
66		28
72		25
78		22
84		19
90		16
36	108	49
42		43
48		39
54		35
60		31
66		27
72		24
78		21
84		18
90		15
36	114	48
42		42
48		38
54		34
60		30
66		26
72		23
78		20
84		17
90		14
36	118	47
42		41
48		37
54		33
60		29
66		25
72		22
78		19
84		16
90		13

- NOTES:
- CHART VALUES PROVIDE MAXIMUM DESIGN PRESSURES ACCORDING TO ASTM E1300 FOR GIVEN GLASS DIMENSIONS 'a' AND 'b' ($a \geq b$, REFER TO DIAGRAM ON SECTION 6.0), AND CH. 17 OF THE FBC FOR SIZES OTHER THAN TESTED.
 - DO NOT EXCEED MULLION CAPACITY SELECTED OR ANCHOR CAPACITY IN DESIGN PRESSURE CHARTS

TUBELITE
DEPENDABLE
LEADERS IN ECO-EFFICIENT STOREFRONT,
CURTAINWALL AND ENTRANCE SYSTEMS

3056 WALKER RIDGE DRIVE N.W.
WALKER, MICHIGAN 49544
PH: 800 866 2227 FX: 616 301 0008

TITLE:
SERIES 400T CURTAIN WALL - SSG
(NON-HVHZ) (NON-IMPACT)

GLAZING DETAILS

PREPARED BY:
BUILDING DROPS, INC.
1900 NE MIAMI CT., STE. 2-15
MIAMI, FL 33132
PH: (954)399-8478
FAX: (954)744-4738
WEB: www.buildingdrops.com

REMARKS	BY	DATE

THE INSTALLATION DETAILS DESCRIBED HEREIN ARE GENERIC AND MAY NOT REFLECT ACTUAL CONDITIONS FOR A SPECIFIC SITE. IF SITE CONDITIONS CAUSE INSTALLATION TO DEVIATE FROM THE REQUIREMENTS DETAILED HEREIN, A LICENSED ENGINEER OR ARCHITECT SHALL PREPARE SITE SPECIFIC DOCUMENTS FOR USE WITH THIS DOCUMENT

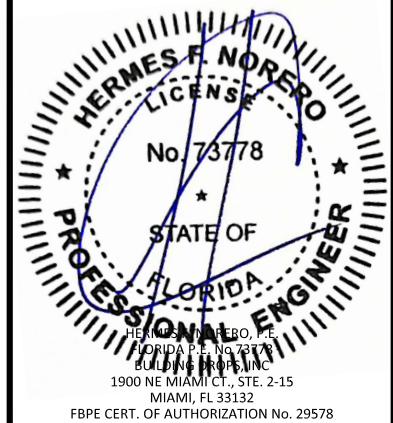

FL #:
FL27506

DATE: **12.21.23**

DWG. BY: **MS** CHK. BY: **HFN**

SCALE: **NTS**

DWG. #: **TLI028**

SECTION
6.1
[PAGE 16 of 25]

s:\projects\tubelite, inc\lbc-23-1221 - fbc submittal - f127506 400t series non-impact curtainwall revisions\dwg\lbc-23-1221.dwg 12/28/2023 1:37 AM

ANCHOR DETAILS

TUBELITE
DEPENDABLE
LEADERS IN ECO-EFFICIENT STOREFRONT,
CURTAINWALL AND ENTRANCE SYSTEMS

3056 WALKER RIDGE DRIVE N.W.
WALKER, MICHIGAN 49544
PH: 800 866 2227 FX: 616 301 0008

ANCHOR SCHEDULE					
TYPE	DIAMETER	ANCHOR TYPE	SUBSTRATE	MINIMUM EMBEDMENT	MINIMUM EDGE DISTANCE
A	1/4"	DEWALT ULTRACON+	3000 PSI CONCRETE	1.75"	2.50"
			2000 PSI MASONRY		
B	3/8"	POWER TAPPER	3000 PSI CONCRETE	1.75"	2.50"
			2000 PSI MASONRY	1.75"	4.50"
C	3/8"	ITW LDT	3000 PSI CONCRETE	1.50"	2.50"
D	3/8"	HILTI KWIK BOLT 3 (CARBON STEEL AND SS)	3000 PSI CONCRETE	1.63"	2.50"
			2000 PSI MASONRY		
E	1/2"	LAG SCREW	2X WOOD MIN. S.G. = 0.55	2.00"	1.00"
F	3/8"	GRADE 5 SELF-DRILLING / SELF-TAPPING SCREW	MIN. 18 GAUGE STEEL STUD (0.0478") 33 KSI OR MIN. 0.08" 6063-T5 ALUMINUM	3 THREADS MIN. ENGAGEMENT	0.75"
G	1/2"	HILTI KWIK BOLT 3 (CARBON STEEL)	3000 PSI CONCRETE	3.50"	3.75"
H	1/2"	DEWALT POWER-BOLT+ (CARBON STEEL AND SS)	3000 PSI CONCRETE	3.50"	3.75"
I	1/2"	GRADE 5 SELF-DRILLING / SELF-TAPPING SCREW	MIN. 1/4" STEEL MIN. FU = 55 KSI OR MIN. 3/8" ALUMINUM 6063-T5	3 THREADS MIN. ENGAGEMENT	1.50"

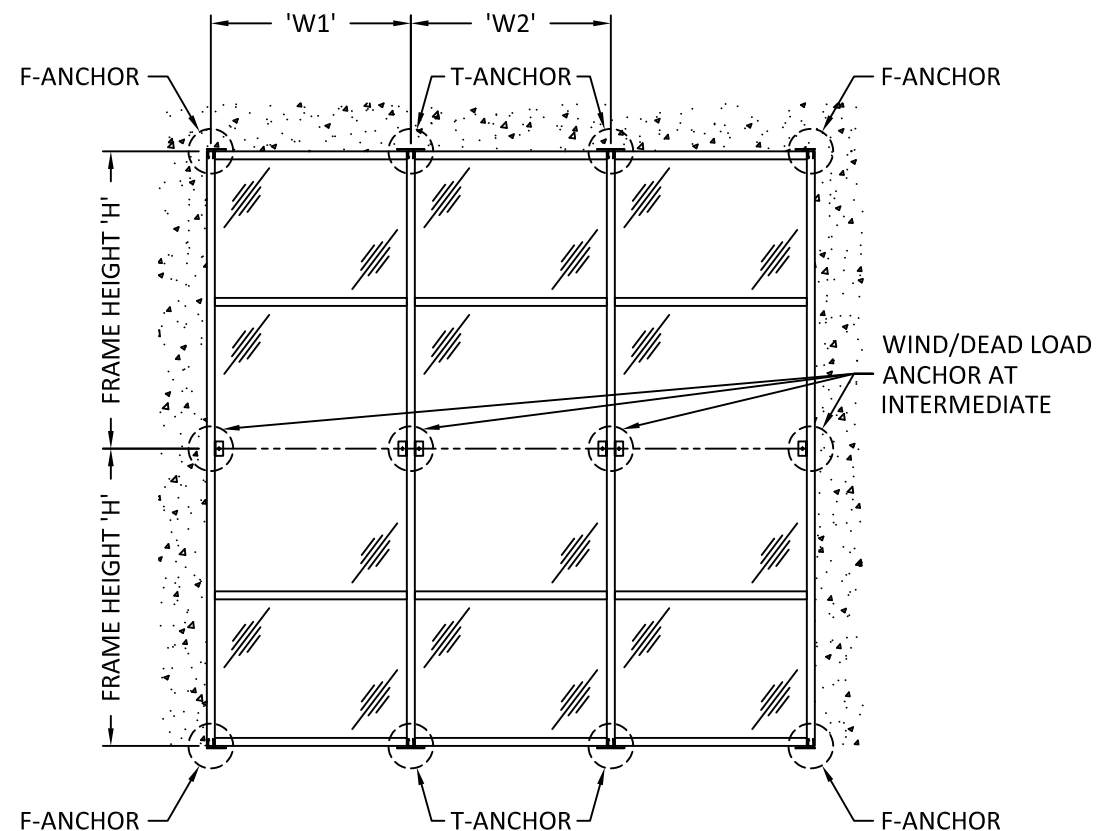
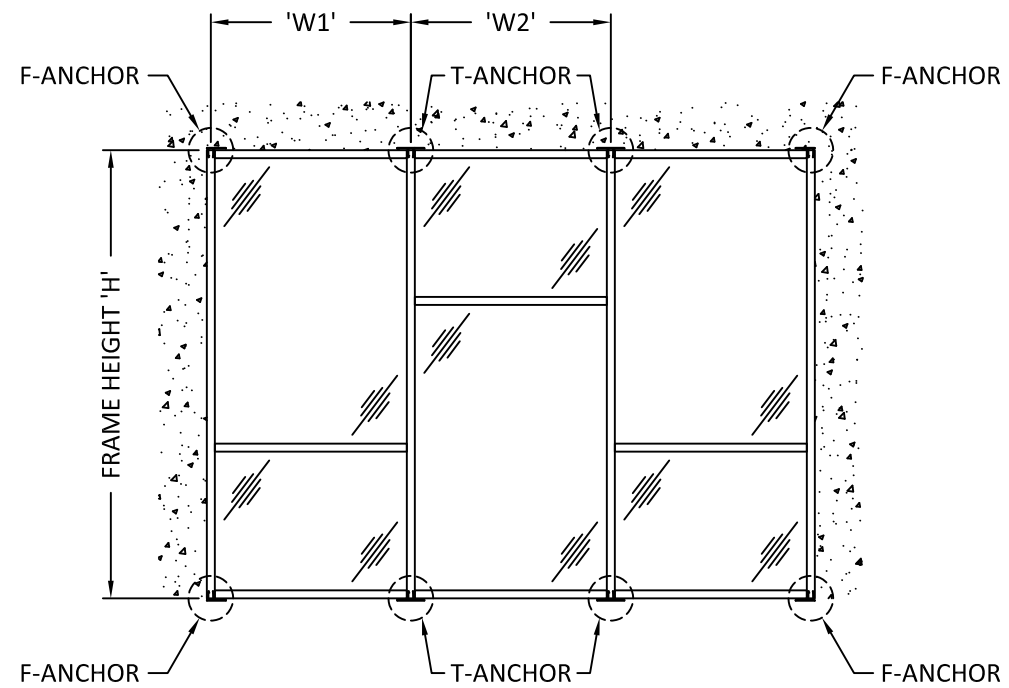

NOTE:

1. ANCHORS SHALL BE INSTALLED IN ACCORDANCE WITH ANCHOR MANUFACTURER'S INSTALLATION INSTRUCTIONS.
2. REFER TO ANCHOR LAYOUTS AT RIGHT FOR LOCATIONS AND DETERMINING MAX. FRAME HEIGHT (H) AND TRIBUTARY WIDTHS (W).
3. FOR SITE CONDITIONS NOT SHOWN IN THE DETAILS HEREIN OR EDGE DISTANCE REQUIREMENTS TO BE MODIFIED, ANCHORS MAY BE ENGINEERED ON A SITE SPECIFIC BASIS.
4. REFER TO SECTION 7 FOR ANCHOR CONFIGURATIONS, T & F ANCHOR TYPE, AND CAPACITIES.
5. REFER TO SECTION 8 FOR WIND/DEAD LOAD ANCHOR CONFIGURATIONS, TYPE, AND CAPACITIES.

MULLION SPACING OR BAY WIDTH, 'W', FOR F-ANCHORS AT JAMBS	W1
MULLION SPACING OR BAY WIDTH, 'W', FOR T-ANCHORS	$\frac{W1 + W2}{2}$
MULLION SPACING OR BAY WIDTH, 'W', FOR F-ANCHORS AT VERTICAL MULL WITH DOORS	$\frac{W1 + W2}{2}$

TITLE: SERIES 400T CURTAIN WALL - SSG (NON-HVHZ) (NON-IMPACT)
ANCHOR DETAILS
PREPARED BY: BUILDING DROPS, INC.
1900 NE MIAMI CT., STE. 2-15
MIAMI, FL 33132
PH: (954)399-8478
FAX: (954)744-4738
WEB: www.buildingdrops.com

REMARKS	BY	DATE

THE INSTALLATION DETAILS DESCRIBED HEREIN ARE GENERIC AND MAY NOT REFLECT ACTUAL CONDITIONS FOR A SPECIFIC SITE. IF SITE CONDITIONS CAUSE INSTALLATION TO DEVIATE FROM THE REQUIREMENTS DETAILED HEREIN, A LICENSED ENGINEER OR ARCHITECT SHALL PREPARE SITE SPECIFIC DOCUMENTS FOR USE WITH THIS DOCUMENT

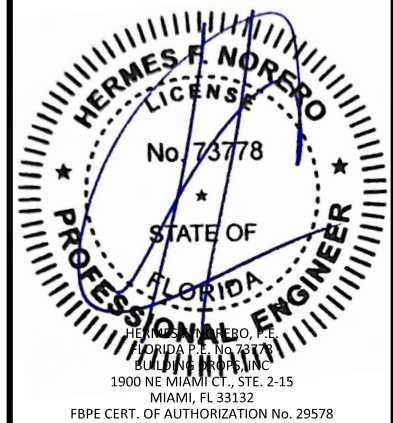

FL #: **FL27506**

DATE: **12.21.23**

DWG. BY: **MS** CHK. BY: **HFN**

SCALE: **NTS**

DWG. #: **TLI028**

SECTION
7.0
[PAGE 17 of 25]

s:\projects\tubelite, inc\lbc-23-1221 - lbc submittal - f127506 400t series non-impact curtainwall revisions\dwg\lbc-23-1221-028.dwg 12/28/2023 1:37 AM

ANCHOR DETAILS

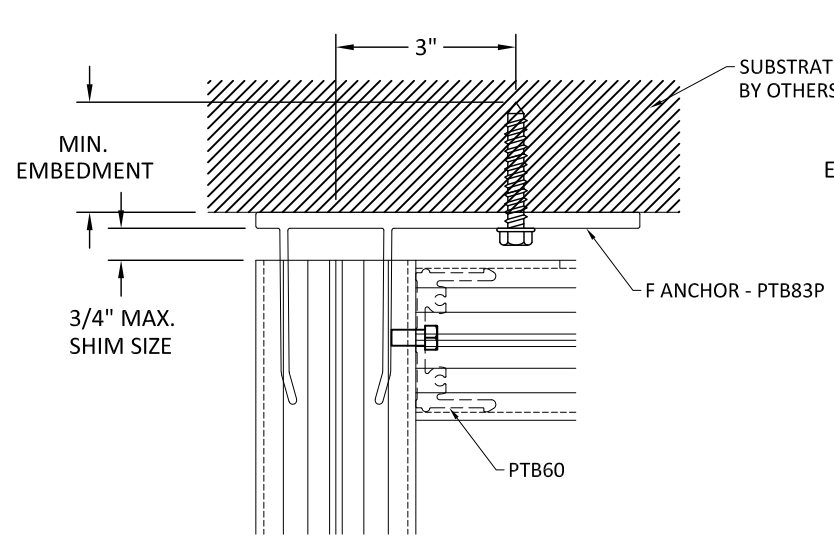

1
7.1
F ANCHOR
ONE FASTENER PER ANCHOR

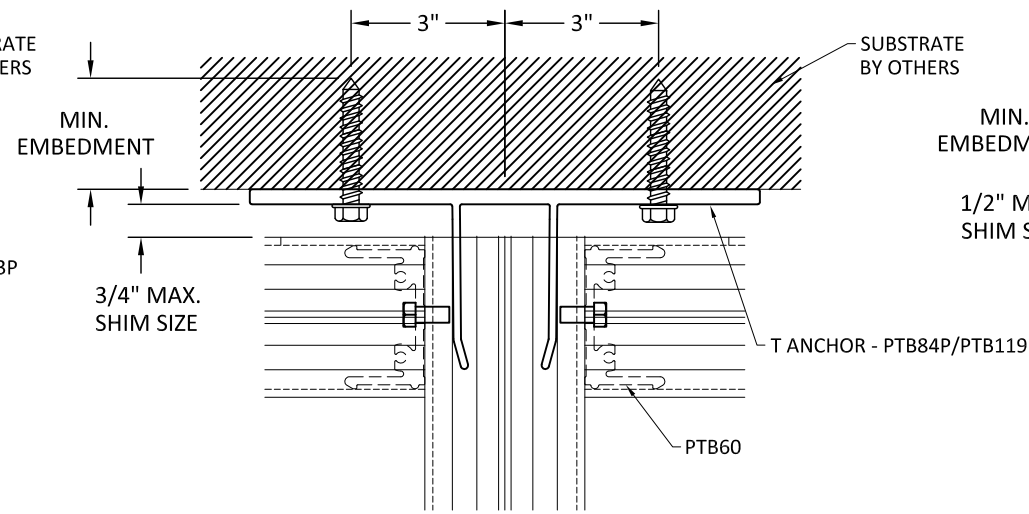

3
7.1
T ANCHOR
TWO FASTENERS PER ANCHOR

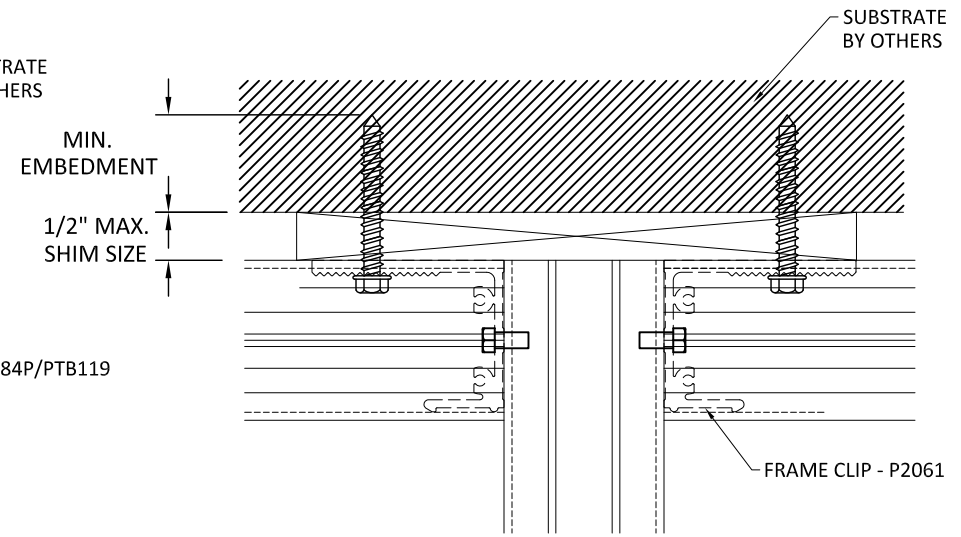

5
7.1
FRAME CLIP
ONE FASTENER PER CLIP

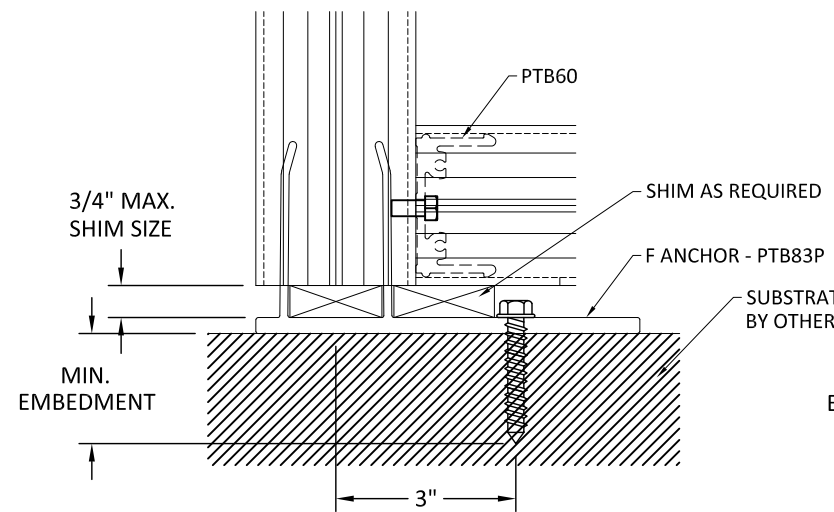

2
7.1
F ANCHOR
ONE FASTENER PER ANCHOR

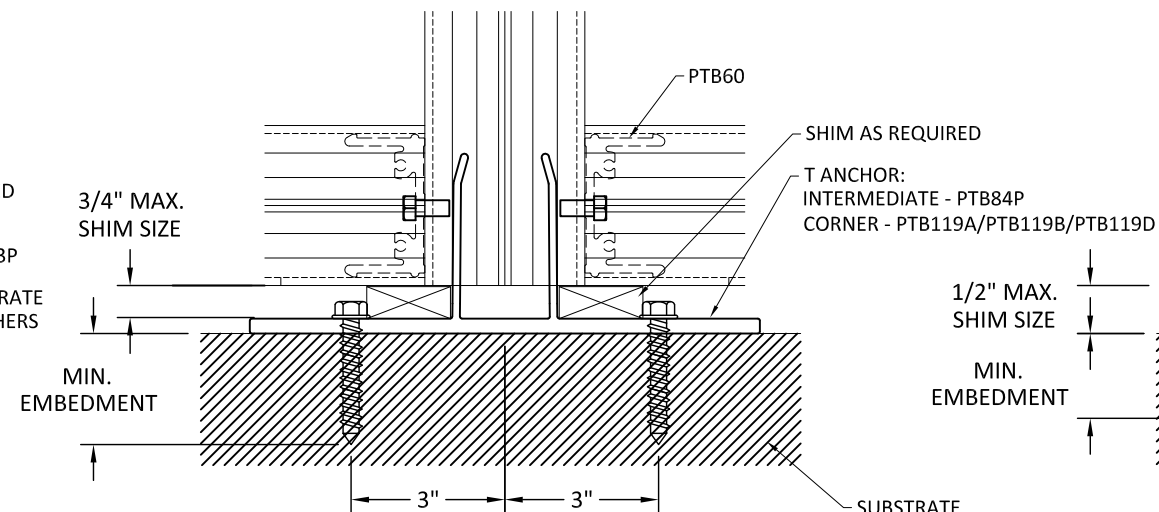

4
7.1
T ANCHOR
TWO FASTENERS PER ANCHOR

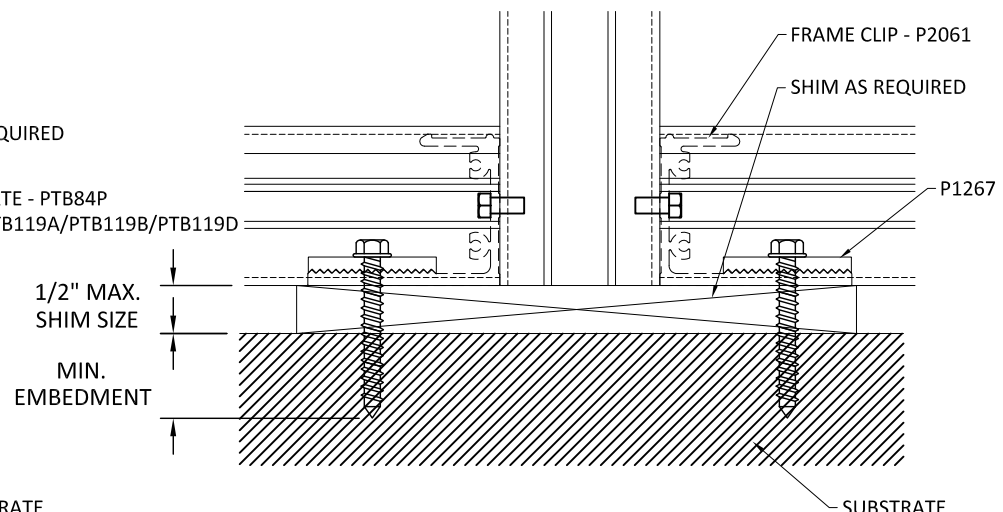

6
7.1
FRAME CLIP
ONE FASTENER PER CLIP

TUBELITE®
DEPENDABLE
LEADERS IN ECO-EFFICIENT STOREFRONT,
CURTAINWALL AND ENTRANCE SYSTEMS

3056 WALKER RIDGE DRIVE N.W.
WALKER, MICHIGAN 49544
PH: 800 866 2227 FX: 616 301 0008

TITLE:
SERIES 400T CURTAIN WALL - SSG
(NON-HVHZ) (NON-IMPACT)

ANCHOR DETAILS

PREPARED BY:
BUILDING DROPS, INC.
1900 NE MIAMI CT., STE. 2-15
MIAMI, FL 33132
PH: (954)399-8478
FAX: (954)744-4738
WEB: www.buildingdrops.com



REMARKS	BY	DATE

THE INSTALLATION DETAILS DESCRIBED HEREIN ARE
GENERIC AND MAY NOT REFLECT ACTUAL CONDITIONS FOR
A SPECIFIC SITE. IF SITE CONDITIONS CAUSE INSTALLATION
TO DEVIATE FROM THE REQUIREMENTS DETAILED HEREIN, A
LICENSED ENGINEER OR ARCHITECT SHALL PREPARE SITE
SPECIFIC DOCUMENTS FOR USE WITH THIS DOCUMENT

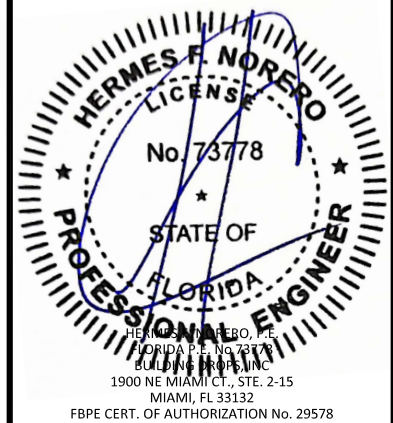

FL #:
FL27506

DATE: **12.21.23**

DWG. BY: **MS** CHK. BY: **HFN**

SCALE: **NTS**

DWG. #: **TLI028**

SECTION
7.1
[PAGE 18 of 25]

12/28/2023 1:37 AM
s:\projects\tubelite, inc\lbc-23-1221 - lbc-submittal- f127506 400t series non-impact curtainwall revisions\dwg\lbc028.dwg

ANCHOR DETAILS

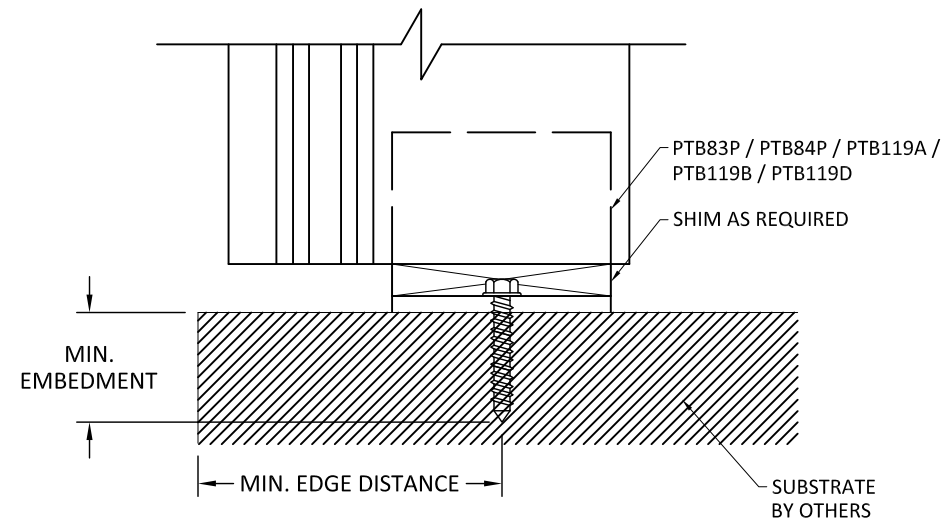

1
7.2 SIDE VIEW
F/T ANCHOR CONNECTION

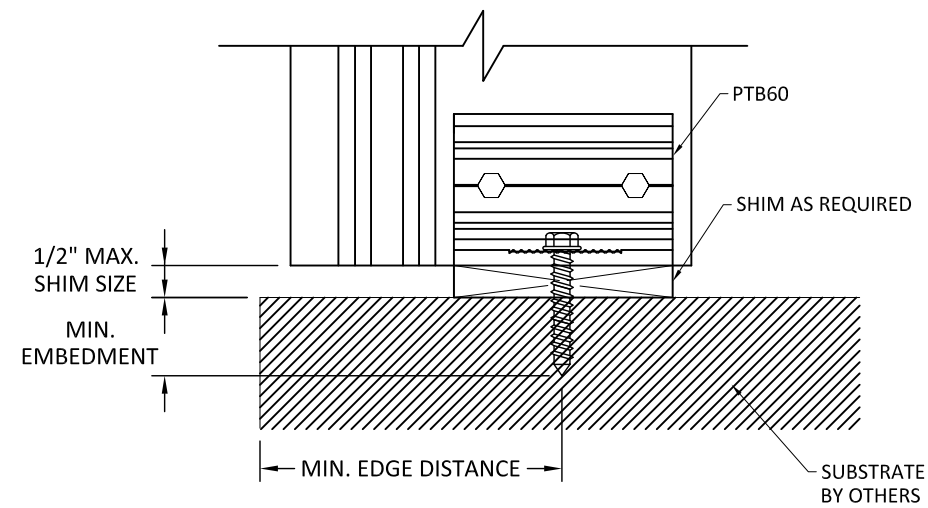

2
7.2 SIDE VIEW
FRAME CLIP CONNECTION

TUBELITE®
DEPENDABLE
LEADERS IN ECO-EFFICIENT STOREFRONT,
CURTAINWALL AND ENTRANCE SYSTEMS

3056 WALKER RIDGE DRIVE N.W.
WALKER, MICHIGAN 49544
PH: 800 866 2227 FX: 616 301 0008

TITLE:
SERIES 400T CURTAIN WALL - SSG
(NON-HVHZ) (NON-IMPACT)

ANCHOR DETAILS

PREPARED BY:
BUILDING DROPS, INC.
1900 NE MIAMI CT., STE. 2-15
MIAMI, FL 33132
PH: (954)399-8478
FAX: (954)744-4738
WEB: www.buildingdrops.com



REMARKS	BY	DATE

THE INSTALLATION DETAILS DESCRIBED HEREIN ARE
GENERIC AND MAY NOT REFLECT ACTUAL CONDITIONS FOR
A SPECIFIC SITE. IF SITE CONDITIONS CAUSE INSTALLATION
TO DEVIATE FROM THE REQUIREMENTS DETAILED HEREIN, A
LICENSED ENGINEER OR ARCHITECT SHALL PREPARE SITE
SPECIFIC DOCUMENTS FOR USE WITH THIS DOCUMENT

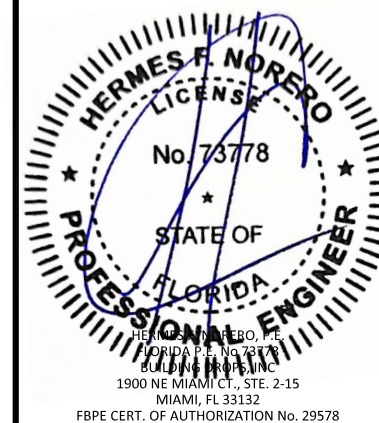

FL #:
FL27506

DATE: **12.21.23**

DWG. BY:
MS

CHK. BY:
HFN

SCALE: **NTS**

DWG. #: **TLI028**

SECTION

7.2

[PAGE 19 of 25]

ANCHOR CAPACITY - T ANCHOR

TUBELITE®
DEPENDABLE
LEADERS IN ECO-EFFICIENT STOREFRONT,
CURTAINWALL AND ENTRANCE SYSTEMS

3056 WALKER RIDGE DRIVE N.W.
WALKER, MICHIGAN 49544
PH: 800 866 2227 FX: 616 301 0008

NOMINAL DIMENSIONS		MAX. MULLION/CORNER DESIGN PRESSURE FOR TWIN SPAN HEAD / SILL CONNECTIONS (+/- PSF)					
WIDTH 'W' (in)	HEIGHT 'H' (in)	ANCHOR A	ANCHOR B	ANCHOR C	ANCHOR D	ANCHOR E	ANCHOR F
24	90	84	100	100	100	100	100
30		67	92	91	100	81	100
36		56	76	76	100	67	100
42		48	65	65	91	57	86
48		42	57	57	79	50	75
54		37	51	50	70	45	67
60		33	46	45	63	40	60
24		96	79	100	100	100	95
30	63		86	85	100	76	100
36	52		72	71	99	63	94
42	45		61	61	85	54	80
48	39		54	53	74	47	70
54	35		48	47	66	42	62
60	31		43	42	59	38	56
24	102		74	100	100	100	89
30		59	81	80	100	71	100
36		49	67	67	93	59	88
42		42	58	57	80	51	76
48		37	50	50	70	44	66
54		33	45	44	62	39	59
60		29	40	40	56	35	53
24		108	70	96	95	100	84
30	56		76	76	100	67	100
36	47		64	63	88	56	83
42	40		54	54	76	48	71
48	35		48	47	66	42	62
54	31		42	42	59	37	55
60	28		38	38	53	33	50
24	114		66	91	90	100	80
30		53	72	72	100	64	95
36		44	60	60	84	53	79
42		38	52	51	72	45	68
48		33	45	45	63	40	59
54		29	40	40	56	35	52
60		26	36	36	50	32	47

NOMINAL DIMENSIONS		MAX. MULLION/CORNER DESIGN PRESSURE FOR TWIN SPAN HEAD / SILL CONNECTIONS (+/- PSF)					
WIDTH 'W' (in)	HEIGHT 'H' (in)	ANCHOR A	ANCHOR B	ANCHOR C	ANCHOR D	ANCHOR E	ANCHOR F
24	120	63	86	85	100	76	100
30		50	69	68	95	60	90
36		42	57	57	79	50	75
42		36	49	48	68	43	64
48		31	43	42	59	38	56
54		28	38	38	53	33	50
60		25	34	34	47	30	45
24		126	60	82	81	100	72
30	48		65	65	91	57	86
36	40		54	54	76	48	71
42	34		47	46	65	41	61
48	30		41	40	57	36	53
54	26		36	36	50	32	47
60	24		32	32	45	28	43
24	132		57	78	77	100	69
30		46	62	62	87	55	82
36		38	52	51	72	46	68
42		32	44	44	62	39	58
48		28	39	38	54	34	51
54		25	34	34	48	30	45
60		23	31	31	43	27	41
24		138	55	75	74	100	66
30	44		60	59	83	52	78
36	36		50	49	69	44	65
42	31		43	42	59	37	56
48	27		37	37	52	33	49
54	24		33	33	46	29	43
60	22		30	29	41	26	39
24	144		52	72	71	99	63
30		42	57	57	79	50	75
36		35	48	47	66	42	62
42		30	41	40	57	36	53
48		26	36	35	49	31	47
54		23	32	31	44	28	41
60		21	28	28	39	25	37

TITLE: SERIES 400T CURTAIN WALL - SSG (NON-HVHZ) (NON-IMPACT)
ANCHOR DETAILS
PREPARED BY: BUILDING DROPS, INC.
1900 NE MIAMI CT., STE. 2-15
MIAMI, FL 33132
PH: (954)399-8478
FAX: (954)744-4738
WEB: www.buildingdrops.com

REMARKS	BY	DATE

THE INSTALLATION DETAILS DESCRIBED HEREIN ARE GENERIC AND MAY NOT REFLECT ACTUAL CONDITIONS FOR A SPECIFIC SITE. IF SITE CONDITIONS CAUSE INSTALLATION TO DEVIATE FROM THE REQUIREMENTS DETAILED HEREIN, A LICENSED ENGINEER OR ARCHITECT SHALL PREPARE SITE SPECIFIC DOCUMENTS FOR USE WITH THIS DOCUMENT

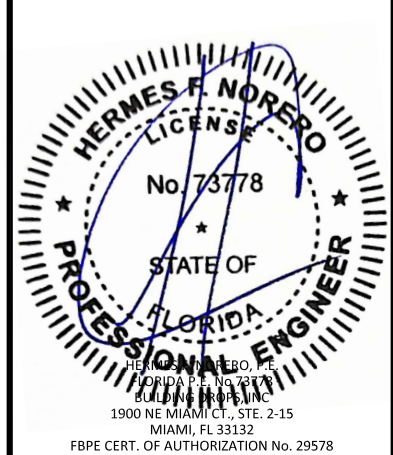

FL #: **FL27506**

DATE: **12.21.23**

DWG. BY: **MS** CHK. BY: **HFN**

SCALE: **NTS**

DWG. #: **TLI028**

SECTION
7.3
[PAGE 20 of 25]

s:\projects\tubelite, inc\lbc-23-1221 - fbc-submittal - f127506 400t series non-impact curtainwall revisions\dwgs\tli028.dwg 12/28/2023 1:37 AM

ANCHOR CAPACITY - F ANCHOR

TUBELITE®
DEPENDABLE

LEADERS IN ECO-EFFICIENT STOREFRONT,
CURTAINWALL AND ENTRANCE SYSTEMS

3056 WALKER RIDGE DRIVE N.W.
WALKER, MICHIGAN 49544
PH: 800 866 2227 FX: 616 301 0008

NOMINAL DIMENSIONS		MAX. JAMB DESIGN PRESSURE FOR TWIN SPAN HEAD/SILL CONNECTIONS (+/- PSF)					
WIDTH 'W' (in)	HEIGHT 'H' (in)	ANCHOR A	ANCHOR B	ANCHOR C	ANCHOR D	ANCHOR E	ANCHOR F
12	90	84	100	100	100	100	100
15		67	92	91	100	81	100
18		56	76	76	100	67	100
21		48	65	65	91	57	86
24		42	57	57	79	50	75
27		37	51	50	70	45	67
30		33	46	45	63	40	60
12	96	79	100	100	100	95	100
15		63	86	85	100	76	100
18		52	72	71	99	63	94
21		45	61	61	85	54	80
24		39	54	53	74	47	70
27		35	48	47	66	42	62
30		31	43	42	59	38	56
12	102	74	100	100	100	89	100
15		59	81	80	100	71	100
18		49	67	67	93	59	88
21		42	58	57	80	51	76
24		37	50	50	70	44	66
27		33	45	44	62	39	59
30		29	40	40	56	35	53
12	108	70	96	95	100	84	100
15		56	76	76	100	67	100
18		47	64	63	88	56	83
21		40	54	54	76	48	71
24		35	48	47	66	42	62
27		31	42	42	59	37	55
30		28	38	38	53	33	50
12	114	66	91	90	100	80	100
15		53	72	72	100	64	95
18		44	60	60	84	53	79
21		38	52	51	72	45	68
24		33	45	45	63	40	59
27		29	40	40	56	35	52
30		26	36	36	50	32	47

NOMINAL DIMENSIONS		MAX. JAMB DESIGN PRESSURE FOR TWIN SPAN HEAD/SILL CONNECTIONS (+/- PSF)					
WIDTH 'W' (in)	HEIGHT 'H' (in)	ANCHOR A	ANCHOR B	ANCHOR C	ANCHOR D	ANCHOR E	ANCHOR F
12	120	63	86	85	100	76	100
15		50	69	68	95	60	90
18		42	57	57	79	50	75
21		36	49	48	68	43	64
24		31	43	42	59	38	56
27		28	38	38	53	33	50
30		25	34	34	47	30	45
12	126	60	82	81	100	72	100
15		48	65	65	91	57	86
18		40	54	54	76	48	71
21		34	47	46	65	41	61
24		30	41	40	57	36	53
27		26	36	36	50	32	47
30		24	32	32	45	28	43
12	132	57	78	77	100	69	100
15		46	62	62	87	55	82
18		38	52	51	72	46	68
21		32	44	44	62	39	58
24		28	39	38	54	34	51
27		25	34	34	48	30	45
30		23	31	31	43	27	41
12	138	55	75	74	100	66	98
15		44	60	59	83	52	78
18		36	50	49	69	44	65
21		31	43	42	59	37	56
24		27	37	37	52	33	49
27		24	33	33	46	29	43
30		22	30	29	41	26	39
12	144	52	72	71	99	63	94
15		42	57	57	79	50	75
18		35	48	47	66	42	62
21		30	41	40	57	36	53
24		26	36	35	49	31	47
27		23	32	31	44	28	41
30		21	28	28	39	25	37

TITLE: SERIES 400T CURTAIN WALL - SSG (NON-HVHZ) (NON-IMPACT)
ANCHOR DETAILS

PREPARED BY: BUILDING DROPS, INC.
1900 NE MIAMI CT., STE. 2-15
MIAMI, FL 33132
PH: (954)399-8478
FAX: (954)744-4738
WEB: www.buildingdrops.com

REMARKS	BY	DATE

THE INSTALLATION DETAILS DESCRIBED HEREIN ARE GENERIC AND MAY NOT REFLECT ACTUAL CONDITIONS FOR A SPECIFIC SITE. IF SITE CONDITIONS CAUSE INSTALLATION TO DEVIATE FROM THE REQUIREMENTS DETAILED HEREIN, A LICENSED ENGINEER OR ARCHITECT SHALL PREPARE SITE SPECIFIC DOCUMENTS FOR USE WITH THIS DOCUMENT

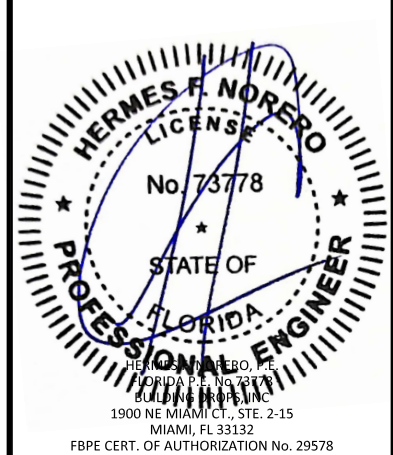

FL #: **FL27506**

DATE: **12.21.23**

DWG. BY: **MS** CHK. BY: **HFN**

SCALE: **NTS**

DWG. #: **TLI028**

SECTION

7.4

[PAGE 21 of 25]

12/28/2023 1:37 AM
s:\projects\tubelite, inc\bc-23-1221 - fbc-submittal - f127506 400t series non-impact curtainwall revisions\dwg\tili028.dwg

WIND/DEAD LOAD ANCHOR

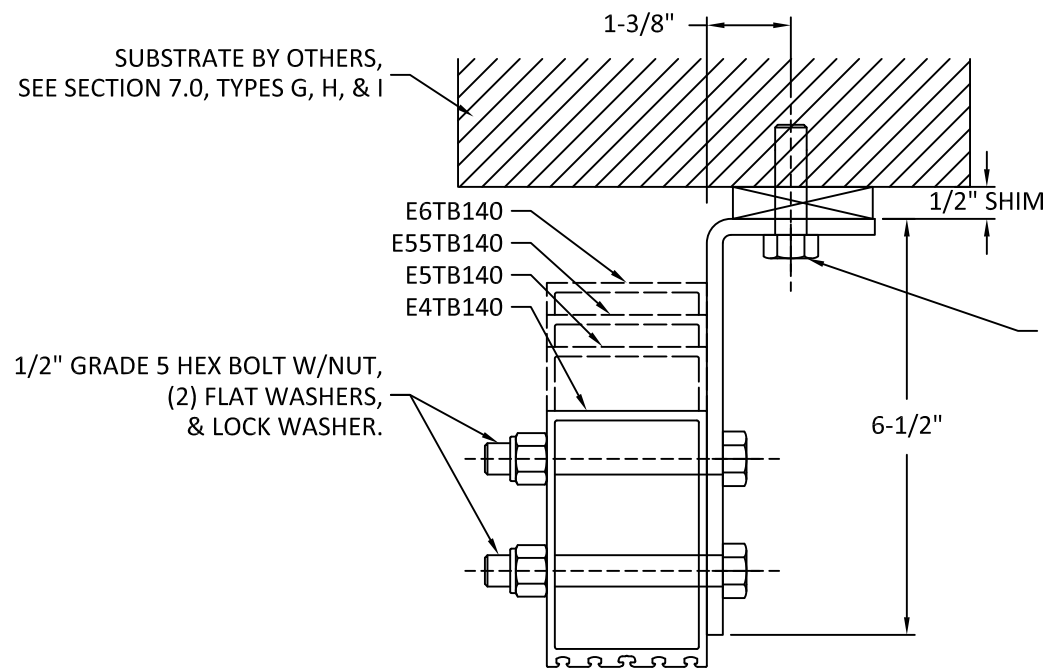

1
8.0 VERTICAL SECTION
WIND/DEAD LOAD ANCHOR
AT JAMB

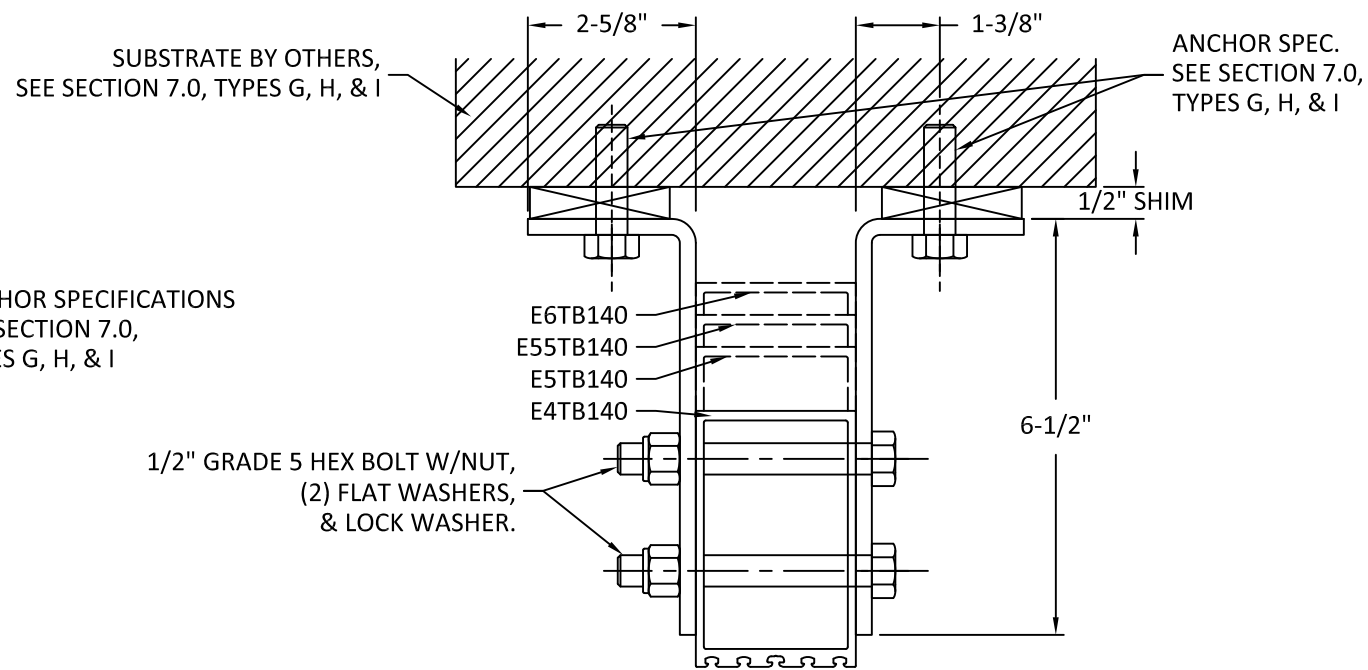

2
8.0 VERTICAL SECTION
WIND/DEAD LOAD ANCHOR
AT INTERMEDIATE

PROFILES E7TB140, E8TB140
ARE SIMILAR AND QUALIFIED.

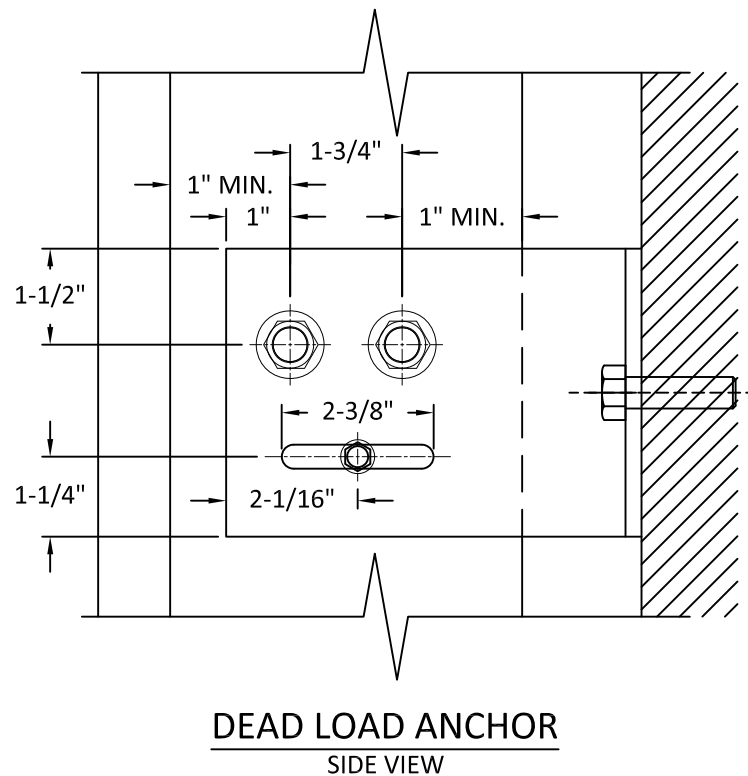

DEAD LOAD ANCHOR
SIDE VIEW

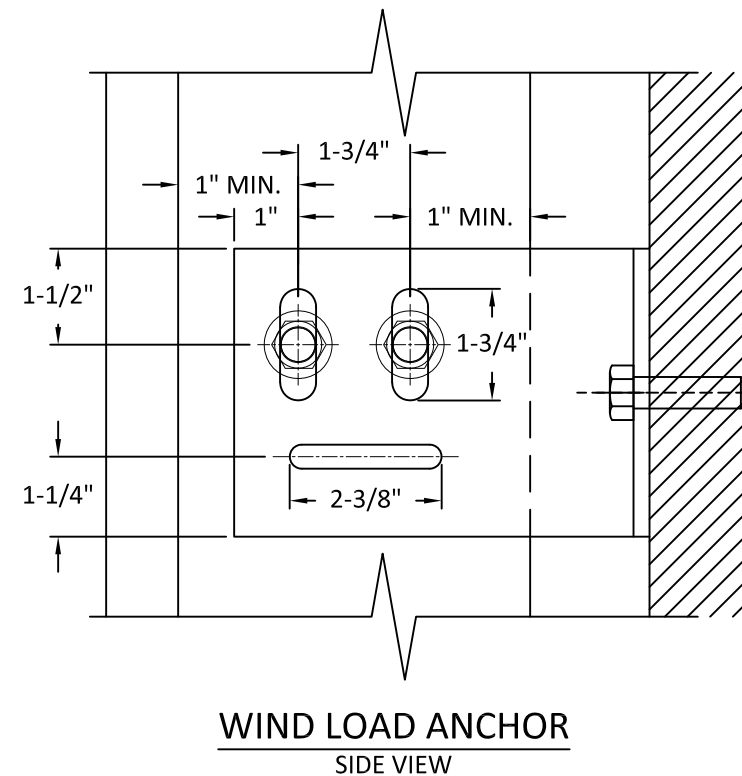

WIND LOAD ANCHOR
SIDE VIEW

TUBELITE
DEPENDABLE
LEADERS IN ECO-EFFICIENT STOREFRONT,
CURTAINWALL AND ENTRANCE SYSTEMS

3056 WALKER RIDGE DRIVE N.W.
WALKER, MICHIGAN 49544
PH: 800 866 2227 FX: 616 301 0008

TITLE: SERIES 400T CURTAIN WALL - SSG
(NON-HVHZ) (NON-IMPACT)
WIND/DEAD LOAD ANCHOR DETAILS
PREPARED BY: BUILDING DROPS, INC.
1900 NE MIAMI CT., STE. 2-15
MIAMI, FL 33132
PH: (954) 399-8478
FAX: (954) 744-4738
WEB: www.buildingdrops.com

REMARKS	BY	DATE

THE INSTALLATION DETAILS DESCRIBED HEREIN ARE
GENERIC AND MAY NOT REFLECT ACTUAL CONDITIONS FOR
A SPECIFIC SITE. IF SITE CONDITIONS CAUSE INSTALLATION
TO DEVIATE FROM THE REQUIREMENTS DETAILED HEREIN, A
LICENSED ENGINEER OR ARCHITECT SHALL PREPARE SITE
SPECIFIC DOCUMENTS FOR USE WITH THIS DOCUMENT

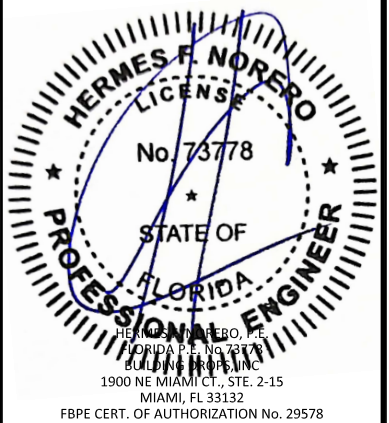

FL #: **FL27506**

DATE: **12.21.23**

DWG. BY: **MS** CHK. BY: **HFN**

SCALE: **NTS**

DWG. #: **TLI028**

SECTION
8.0
[PAGE 22 of 25]

WIND/DEAD LOAD ANCHOR

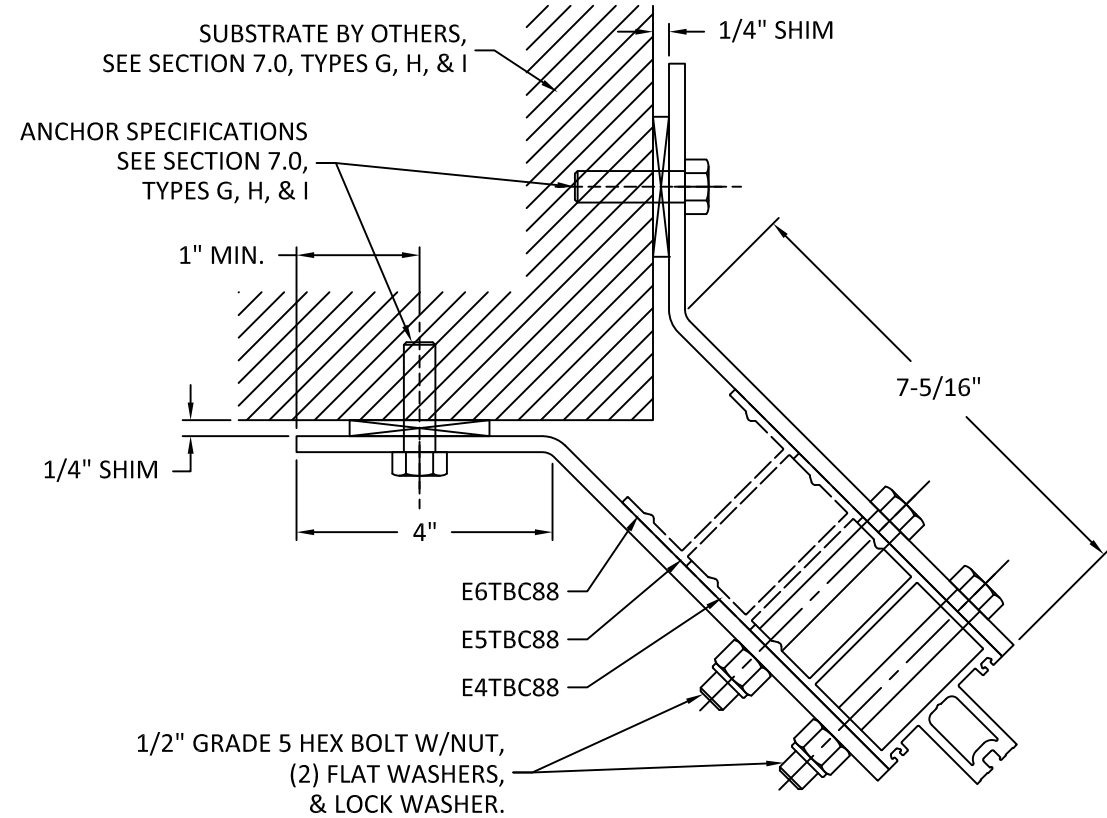

1
8.1 VERTICAL SECTION
WIND/DEAD LOAD ANCHOR
AT CORNER

1/2" GRADE 5 HEX BOLT W/NUT,
(2) FLAT WASHERS,
& LOCK WASHER.

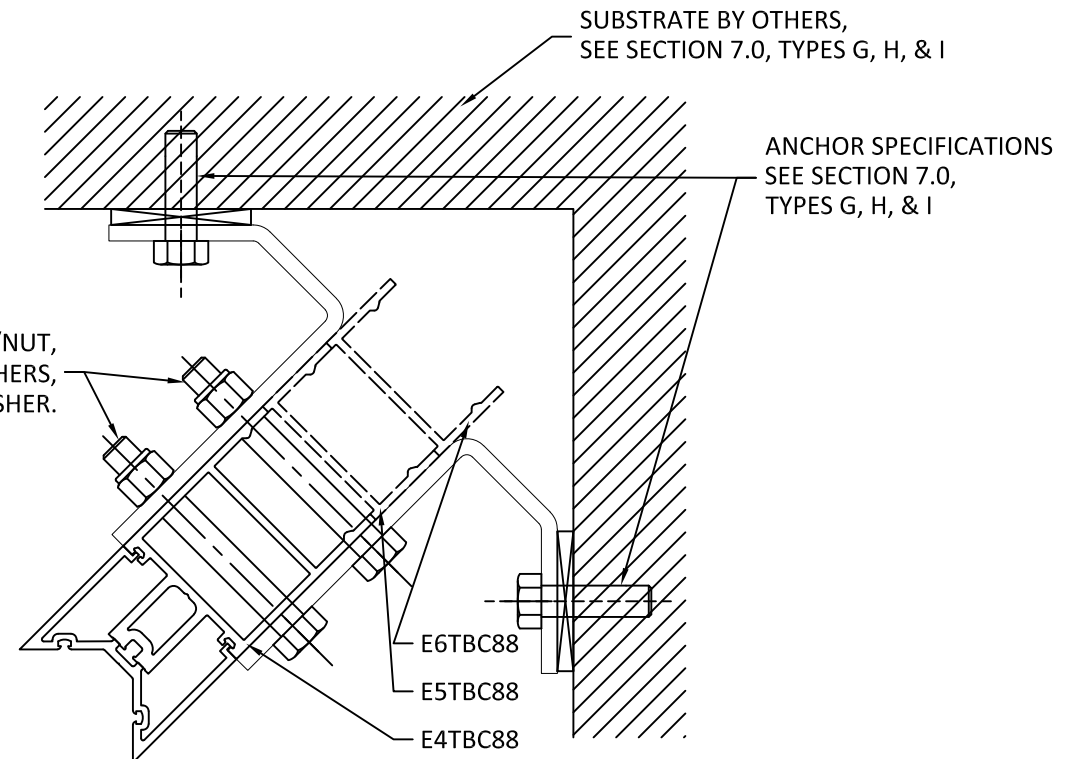

2
8.1 VERTICAL SECTION
WIND/DEAD LOAD ANCHOR
AT CORNER

PROFILES E7TBC88, E8TBC88
ARE SIMILAR AND QUALIFIED.

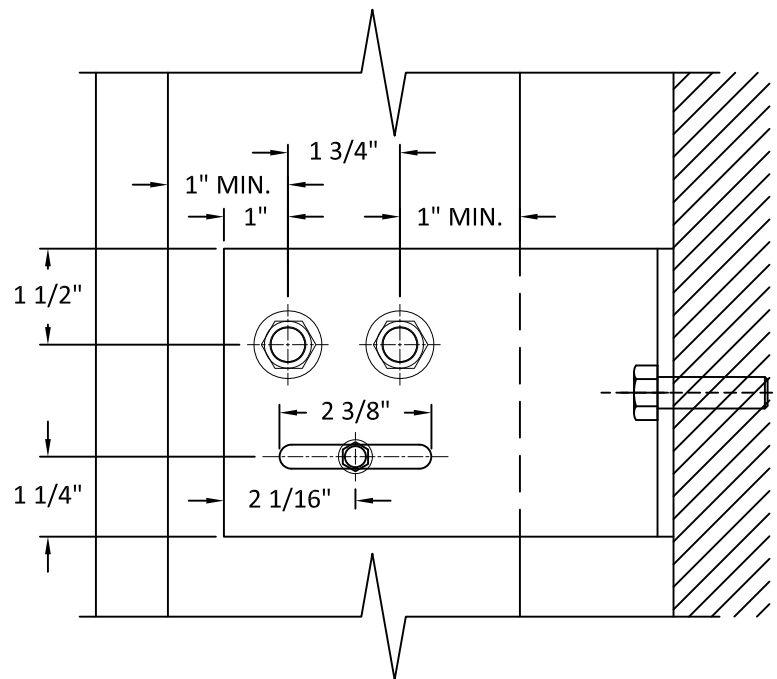

DEAD LOAD ANCHOR
SIDE VIEW

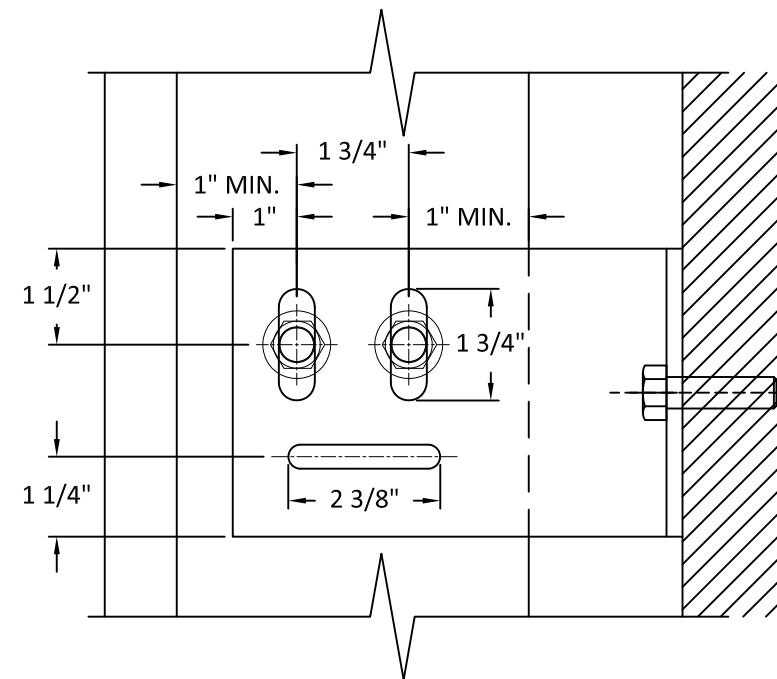

WIND LOAD ANCHOR
SIDE VIEW

TUBELITE®
DEPENDABLE
LEADERS IN ECO-EFFICIENT STOREFRONT,
CURTAINWALL AND ENTRANCE SYSTEMS

3056 WALKER RIDGE DRIVE N.W.
WALKER, MICHIGAN 49544
PH: 800 866 2227 FX: 616 301 0008

TITLE:
SERIES 400T CURTAIN WALL - SSG
(NON-HVHZ) (NON-IMPACT)

WIND/DEAD LOAD ANCHOR DETAILS

PREPARED BY:
BUILDING DROPS, INC.
1900 NE MIAMI CT., STE. 2-15
MIAMI, FL 33132
PH: (954) 399-8478
FAX: (954) 744-4738
WEB: www.buildingdrops.com



REMARKS	BY	DATE

THE INSTALLATION DETAILS DESCRIBED HEREIN ARE
GENERIC AND MAY NOT REFLECT ACTUAL CONDITIONS FOR
A SPECIFIC SITE. IF SITE CONDITIONS CAUSE INSTALLATION
TO DEVIATE FROM THE REQUIREMENTS DETAILED HEREIN, A
LICENSED ENGINEER OR ARCHITECT SHALL PREPARE SITE
SPECIFIC DOCUMENTS FOR USE WITH THIS DOCUMENT

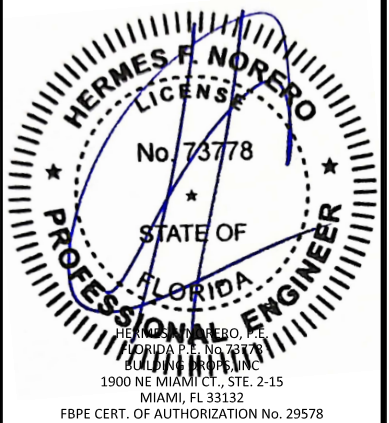

FL #:
FL27506

DATE: **12.21.23**

DWG. BY: **MS** CHK. BY: **HFN**

SCALE: **NTS**

DWG. #: **TLI028**

SECTION
8.1
[PAGE 23 of 25]

s:\projects\tubelite, inc\lbc-23-1221 - fbc submittal - f127506 400t series non-impact curtainwall revisions\dwg\lbc23.dwg 12/28/2023 1:37 AM

WIND/DEAD LOAD ANCHOR CAPACITY - MULLION & CORNER

TUBELITE®
DEPENDABLE
LEADERS IN ECO-EFFICIENT STOREFRONT,
CURTAINWALL AND ENTRANCE SYSTEMS

3056 WALKER RIDGE DRIVE N.W.
WALKER, MICHIGAN 49544
PH: 800 866 2227 FX: 616 301 0008

NOMINAL DIMENSIONS		MAX. MULLION DESIGN PRESSURE FOR TWIN SPAN INTERMEDIATE CONNECTIONS (+/- PSF)		
WIDTH 'W' (in)	HEIGHT 'H' (in)	ANCHOR G	ANCHOR H	ANCHOR I
24	90	100	100	100
30		100	100	100
36		100	92	100
42		88	78	100
48		76	68	100
54		66	60	88
60		60	53	78
24	96	100	100	100
30		100	100	100
36		96	86	100
42		82	73	100
48		70	63	93
54		62	55	82
60		56	49	73
24	102	100	100	100
30		100	97	100
36		90	80	100
42		76	68	100
48		66	59	87
54		58	52	77
60		52	46	68
24	108	100	100	100
30		100	92	100
36		84	76	100
42		72	64	95
48		62	55	82
54		54	49	72
60		48	43	64
24	114	100	100	100
30		98	87	100
36		80	71	100
42		68	60	89
48		58	52	77
54		52	46	68
60		46	41	60

NOMINAL DIMENSIONS		MAX. MULLION DESIGN PRESSURE FOR TWIN SPAN INTERMEDIATE CONNECTIONS (+/- PSF)		
WIDTH 'W' (in)	HEIGHT 'H' (in)	ANCHOR G	ANCHOR H	ANCHOR I
24	120	100	100	100
30		92	82	100
36		76	68	100
42		64	57	84
48		56	49	73
54		48	43	64
60		44	38	57
24	126	100	98	100
30		88	78	100
36		72	64	95
42		62	54	80
48		52	47	69
54		46	41	60
60		40	36	53
24	132	100	94	100
30		84	74	100
36		68	61	90
42		58	51	76
48		50	44	65
54		44	39	57
60		38	34	50
24	138	100	89	100
30		80	71	100
36		66	58	86
42		56	49	72
48		48	42	62
54		42	37	54
60		36	32	48
24	144	96	86	100
30		76	68	100
36		62	55	82
42		52	47	69
48		46	40	59
54		40	35	52
60		34	31	45

TITLE: SERIES 400T CURTAIN WALL - SSG (NON-HVHZ) (NON-IMPACT)
WIND/DEAD LOAD ANCHOR DETAILS

PREPARED BY: BUILDING DROPS, INC.
1900 NE MIAMI CT., STE. 2-15
MIAMI, FL 33132
PH: (954)399-8478
FAX: (954)744-4738
WEB: www.buildingdrops.com

REMARKS	BY	DATE

THE INSTALLATION DETAILS DESCRIBED HEREIN ARE GENERIC AND MAY NOT REFLECT ACTUAL CONDITIONS FOR A SPECIFIC SITE. IF SITE CONDITIONS CAUSE INSTALLATION TO DEVIATE FROM THE REQUIREMENTS DETAILED HEREIN, A LICENSED ENGINEER OR ARCHITECT SHALL PREPARE SITE SPECIFIC DOCUMENTS FOR USE WITH THIS DOCUMENT

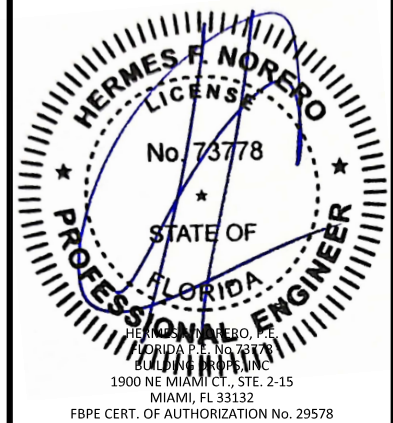

FL #: **FL27506**

DATE: **12.21.23**

DWG. BY: **MS** CHK. BY: **HFN**

SCALE: **NTS**

DWG. #: **TLI028**

SECTION
8.2
[PAGE 24 of 25]

s:\projects\tubelite, inc\lbc-23-1221 - fbc submittal - f127506 400t series non-impact curtainwall revisions\dwgs\tli028.dwg 12/28/2023 1:37 AM

WIND/DEAD LOAD ANCHOR CAPACITY - JAMB

TUBELITE
DEPENDABLE
LEADERS IN ECO-EFFICIENT STOREFRONT,
CURTAINWALL AND ENTRANCE SYSTEMS

3056 WALKER RIDGE DRIVE N.W.
WALKER, MICHIGAN 49544
PH: 800 866 2227 FX: 616 301 0008

NOMINAL DIMENSIONS		MAX. JAMB DESIGN PRESSURE FOR TWIN SPAN INTERMEDIATE CONNECTIONS (+/- PSF)		
WIDTH 'W' (in)	HEIGHT 'H' (in)	ANCHOR G	ANCHOR H	ANCHOR I
12	90	100	100	100
15		100	100	100
18		100	93	100
21		89	79	100
24		78	69	100
27		69	61	91
30		62	55	81
12	96	100	100	100
15		100	100	100
18		98	87	100
21		84	74	100
24		73	65	96
27		65	57	85
30		58	51	76
12	102	100	100	100
15		100	99	100
18		92	82	100
21		79	70	100
24		69	61	90
27		61	54	80
30		55	48	71
12	108	100	100	100
15		100	93	100
18		87	77	100
21		74	66	97
24		65	57	85
27		57	51	75
30		51	46	67
12	114	100	100	100
15		99	88	100
18		82	73	100
21		70	62	92
24		61	54	80
27		54	48	71
30		49	43	64

NOMINAL DIMENSIONS		MAX. JAMB DESIGN PRESSURE FOR TWIN SPAN INTERMEDIATE CONNECTIONS (+/- PSF)		
WIDTH 'W' (in)	HEIGHT 'H' (in)	ANCHOR G	ANCHOR H	ANCHOR I
12	120	100	100	100
15		94	84	100
18		78	69	100
21		67	59	87
24		58	51	76
27		51	46	67
30		46	41	60
12	126	100	100	100
15		89	79	100
18		74	66	97
21		63	56	83
24		55	49	72
27		49	43	64
30		44	39	57
12	132	100	95	100
15		85	76	100
18		71	63	93
21		60	54	79
24		53	47	69
27		47	41	61
30		42	37	54
12	138	100	91	100
15		82	72	100
18		68	60	89
21		58	51	76
24		50	44	66
27		44	39	58
30		40	35	52
12	144	98	87	100
15		78	69	100
18		65	57	85
21		55	49	72
24		48	43	63
27		42	38	55
30		38	34	50

TITLE: SERIES 400T CURTAIN WALL - SSG (NON-HVHZ) (NON-IMPACT)
WIND/DEAD LOAD ANCHOR DETAILS

PREPARED BY: BUILDING DROPS, INC.
1900 NE MIAMI CT., STE. 2-15
MIAMI, FL 33132
PH: (954)399-8478
FAX: (954)744-4738
WEB: www.buildingdrops.com

REMARKS	BY	DATE

THE INSTALLATION DETAILS DESCRIBED HEREIN ARE GENERIC AND MAY NOT REFLECT ACTUAL CONDITIONS FOR A SPECIFIC SITE. IF SITE CONDITIONS CAUSE INSTALLATION TO DEVIATE FROM THE REQUIREMENTS DETAILED HEREIN, A LICENSED ENGINEER OR ARCHITECT SHALL PREPARE SITE SPECIFIC DOCUMENTS FOR USE WITH THIS DOCUMENT

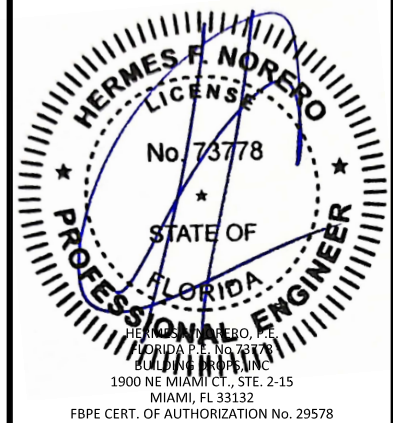

FL #: **FL27506**

DATE: **12.21.23**

DWG. BY: **MS** CHK. BY: **HFN**

SCALE: **NTS**

DWG. #: **TLI028**

SECTION
8.3
[PAGE 25 of 25]

12/28/2023 1:37 AM
s:\projects\tubelite, inc\lbc-23-1221 - fbc submittal - f127506 400t series non-impact curtainwall revisions\dwg\lbc28.dwg